

DCS800-EP Installation and Start Up Manual

DCS800 Panel Drive (20-1000 Amps)
A supplement to the DCS800 Hardware manual



ABB

Safety instructions

What this chapter contains

This chapter contains the safety instructions which you must follow when installing, operating and servicing the drive. If ignored, physical injury or death may follow, or damage may occur to the drive, the motor or driven equipment. Read the safety instructions before you work on the unit.

To which products this chapter applies

This chapter applies to the DCS800-EP... Size D1 to D4.

Use of warnings and notes

There are two types of safety instructions throughout this manual: warnings and notes. Warnings caution you about conditions which can result in serious injury or death and/or damage to the equipment. They also tell you how to avoid the danger. Notes draw attention to a particular condition or fact, or give information on a subject. The warning symbols are used as follows:



Dangerous voltage warning warns of high voltage which can cause physical injury and/or damage to the equipment.



General warning warns about conditions, other than those caused by electricity, which can result in physical injury and/or damage to the equipment.



Electrostatic discharge warning warns of electrostatic discharge which can damage the equipment.

Installation and maintenance work

These warnings are intended for all who work on the drive, motor cable or motor. Ignoring the instructions can cause physical injury or death.



Only qualified electricians are allowed to install and maintain the drive.

- Never work on the drive, motor cable or motor when main power is applied.
 - Always ensure by measuring with a multimeter (impedance at least 1 Mohm) that:
 1. Voltage between drive input phases U1, V1 and W1 and the frame is close to 0 V.
 2. Voltage between terminals C1 and D1 and the frame is close to 0 V.
 - Do not work on the control cables when power is applied to the drive or to the external control circuits. Externally supplied control circuits may cause dangerous voltages inside the drive even when the main power on the drive is switched off.
-

- Do not make any insulation or voltage withstand tests on the drive or drive modules.
 - When reconnecting the motor cable, always check that the C1 and D1 terminal is correct.
-

Note:

- The motor cable terminals on the drive are at a dangerously high voltage when the input power is on, regardless of whether the motor is running or not.
 - Depending on the external wiring, dangerous voltages (115 V, 220 V or 230 V) may be present on the terminals of relay outputs SDCS-IOB-2, RDIO.
 - DCS800 with enclosure extension: Before working on the drive, isolate the whole drive from the supply.
-

Grounding

WARNING! Printed circuit boards contain components sensitive to electrostatic discharge. Wear a grounding wrist band when handling the boards. Do not touch the boards unnecessarily.

These instructions are intended for all who are responsible for the grounding of the drive. Incorrect grounding can cause physical injury, death or equipment malfunction and increase electromagnetic interference.



- Ground the drive, motor and adjoining equipment to ensure personnel safety in all circumstances, and to reduce electromagnetic emission and pick-up.
 - Make sure that grounding conductors are adequately sized as required by safety regulations.
 - In a multiple-drive installation, connect each drive separately to protective earth (PE).
 - Minimize EMC emission and make a 360° high frequency grounding of screened cable entries at the cabinet lead-through.
 - Do not install a drive with EMC filter on an ungrounded power system or a high resistance-grounded (over 30 ohms) power system.
-

Note:

- Power cable shields are suitable for equipment grounding conductors only when adequately sized to meet safety regulations.
 - As the normal leakage current of the drive is higher than 3.5 mA AC or 10 mA DC (stated by EN 50178, 5.2.11.1), a fixed protective earth connection is required.
-

Fiber optic cables



WARNING! Handle the fiber optic cables with care. When unplugging optic cables, always grab the connector, not the cable itself. Do not touch the ends of the fibers with bare hands as the fiber is extremely sensitive to dirt. The minimum allowed bend radius is 35 mm (1.4 in.).

Mechanical installation



These notes are intended for all who install the drive. Handle the unit carefully to avoid damage and injury.

- DCS800-EP Frames A and B: The drives are heavy and may require more than one person to lift. Use appropriate lifting techniques. Do not lift the unit by the front cover. Place the unit only on its back.
 - DCS800-EP Frames C and D: The drive is heavy. Lift the drive by the lifting lugs only.
 - Make sure that dust from drilling does not enter the drive when installing. Electrically conductive dust inside the unit may cause damage or lead to malfunction.
 - Ensure sufficient cooling.
 - Do not fasten the drive by riveting or welding.
-

Operation

These warnings are intended for all who plan the operation of the drive or operate the drive. Ignoring the instructions can cause physical injury or death or damage the equipment.



- Before adjusting the drive and putting it into service, make sure that the motor and all driven equipment are suitable for operation throughout the speed range provided by the drive. The drive can be adjusted to operate the motor at speeds above and below the base speed.
- Do not activate automatic fault reset functions of the Standard Application Program if dangerous situations can occur. When activated, these functions will reset the drive and resume operation after a fault.
- Do not control the motor with the disconnecting device (disconnecting switch); instead, use the control panel keys and / or commands via the I/O board of the drive.
- **Mains connection**
You can use a switch disconnect in the power supply of the thyristor power converter to disconnect the electrical components of the unit from the power supply for installation and maintenance work. The type of disconnect used must be a switch disconnect as per EN 60947-3, Class B, so as to comply with EU regulations, or a circuit-breaker type which switches off the load circuit by means of an auxiliary contact causing the breaker's main contacts to open. The mains disconnect must be locked in its "OPEN" position during any installation and maintenance work.
- EMERGENCY STOP buttons must be installed at each control desk and at all other control panels requiring an emergency stop function. Pressing the STOP button on the control panel of the thyristor power converter will neither cause an emergency motor stop, nor will the drive be disconnected from any dangerous potential.

To avoid unintentional operating states, or to shut the unit down in case of any imminent danger, according to the standards in the safety instructions it is not sufficient to merely shut down the drive via signals "RUN", "Drive OFF" or "Emergency Stop" with "Control Panel" or "PC Tool".

- **Intended use**
The operating instructions cannot take into consideration every possible system configuration, operation or maintenance. Thus, they mainly give such advice only, which is required by qualified personnel for normal operation of the machines and devices in industrial installations.

If in special cases the electrical machines and devices are intended for use in non-industrial installations - which may require stricter safety regulations (e.g. protection against contact by children or similar). These additional safety measures for the installation must be provided by the customer during assembly.



Note:

When the control location is not set to Local (L not shown in the PC tool status row), the **Stop** key on the control panel **WILL NOT** stop the drive.

Table of contents

Safety instructions	2
Use of warnings and notes	2
Installation and maintenance work	2
Mechanical installation	4
Operation	5
Table of contents	6
The DCS800-EP	8
Type codes and Plus Codes	9
Options	10
Other DCS800 documentation	10
Mechanical installation	11
Unpacking the unit	11
Delivery check	11
Requirements for installation	12
Cabinet cooling and air flow	13
Panel heat dissipation	13
Planning the electrical installation	14
Options for the drive	14
Typical cable sizing and tightening torque	16
Electrical installation	17
Checking the insulation of the assembly	17
IT (ungrounded) systems	18
Check supply voltages	18
Connecting the power cables	18
Connection diagram	20
Control circuit connections	21
Alternate line voltage (converting to 230 Vac line)	22
Installation checklist	23
Check	23
Dimensions and weight	24
Dimensional and weight data	24
Dimensional drawings	25
Replacement parts	29
Fuses	29
Fuse tightening torque for AC in (F1 – F3) and DC out (F7 – F8) fuses	29
Blower motor starter	30

Other replacement parts	30
Technical data	31
Electrical and environmental data	31
Specifications	31
Accessories	33
Line reactors	33
Diagrams	34
Power diagram	34
Control diagram	35
Appendix 1 — Operating instructions for blower motor thermal overload relay	37
Index	43

The DCS800-EP

What this chapter contains

This chapter briefly describes the operating principle and construction of the DCS800-EP Panel Drive.

The DCS800-EP

The DCS800-EP sizes A through D are intended as a pre-packaged or “panelized” solution for controlling DC motors.



Size D
400...600 hp

Size C
200...300 hp

Size B
75...150 hp

Size A
10...60 hp

Type codes and plus codes

The type code contains information on the specifications and configuration of the drive. The first digits from left express the basic configuration (e.g. DCS800-EP2-0050). The optional selections are given thereafter, on the name plate by plus code. The main selections are described below. Not all selections are available for all types.

Type code: D C S 8 0 0 - EP X - Y Y Y Y - Z Z - plus code

The “P” in the type code designates the panel drive configuration. Further explanation of the type code can be found in the DCS800 Hardware Manual in the chapter “The DCS800.”

Non-Regenerative (2Q)	Regenerative (4Q)	Module Frame	Panel Frame	460Vac/500Vdc*			230Vac/240Vdc*		
				HP	IAC (amps)	IDC (amps)	HP	IAC (amps)	IDC (amps)
DCS800-EP1-0020-05	DCS800-EP2-0025-05	D1	A	10	14	17	5	16	20
DCS800-EP1-0045-05	DCS800-EP2-0050-05	D1	A	20	29	35	10	30	37
DCS800-EP1-0065-05	DCS800-EP2-0075-05	D1	A	30	43	53	15	44	54
DCS800-EP1-0090-05	DCS800-EP2-0100-05	D1	A	40	55	68	20	58	71
DCS800-EP1-0125-05	DCS800-EP2-0140-05	D1	A	60	85	104	30	85	104
DCS800-EP1-0180-05	–	D2	B	75	102	125	35	102	125
–	DCS800-EP2-0200-05	D2	B	100	134	164	50	143	175
DCS800-EP1-0230-05	DCS800-EP2-0260-05	D2	B	125	167	205	60	168	206
DCS800-EP1-0315-05	DCS800-EP2-0350-05	D3	B	150	200	245	75	208	255
DCS800-EP1-0405-05	–	D3	C	200	265	325	100	278	341
–	DCS800-EP2-0450-05	D3	C	200	265	325	100	278	341
DCS800-EP1-0470-05	DCS800-EP2-0520-05	D3	C	250	330	405	125	347	425
DCS800-EP1-0610-05	–	D4	C	300	392	480	150	413	506
–	DCS800-EP2-0680-05	D4	C	300	392	480	150	413	506
DCS800-EP1-0740-05	DCS800-EP2-0820-05	D4	D	400	522	640			
DCS800-EP1-0900-05	DCS800-EP2-1000-05	D4	D	500	649	795			
–	DCS800-EP2-1010-05	D4	D	600	775	950			

Power and current ratings above are based on Heavy Duty rating, 150% overload for 60 sec., except for 600 HP drive which is rated at 110% overload for 60 sec.

*DC Amps based on standard NEMA motor tables. AC Amps = DC Amps * 0.816



IMPORTANT:

Do not exceed the continuous and overload current ratings shown above. The drive panel is not designed to withstand higher currents. Failure to adhere to this warning can result in personal injury and/or damage to equipment.

Options

	Plus Code	Option Kit
1. Circuit Breaker (All Sizes)	+F278	NA
2. AC Line Reactor DCS800-EP1-0020-05 through DCS800-EP2-0350-05	+E213	NA
3. Without AC Line Contactor DCS800-EP1-0020-05 through DCS800-EP2-0680-05	+0F250	NA
4. 230 Vac supply voltage	+S235	DCS800-EP 230VAC Supply-1
5. Fan/blower motor starters – panel frames A and B		
1.0 – 1.3 Amps	+M635	NA
1.3 – 1.7 Amps	+M636	NA
1.7 – 2.3 Amps	+M637	NA
2.3 – 3.1 Amps	+M638	NA
3.1 – 4.2 Amps	+M639	NA
4.2 – 5.7 Amps	+M640	NA
5.7 – 7.6 Amps	+M641	NA
6. Fan/blower motor starters – panel frame C		
1.3 – 1.8 Amps	+M611	NA
1.7 – 2.1 Amps	+M612	NA
2.2 – 3.1 Amps	+M613	NA
2.8 – 4.0 Amps	+M614	NA
3.5 – 5.0 Amps	+M615	NA
4.5 – 6.5 Amps	+M616	NA
6.0 – 8.5 Amps	+M617	NA
7.5 – 11 Amps	+M618	NA
10 – 14 Amps	+M619	NA
13 – 19 Amps	+M620	NA
18 – 25 Amps	+M621	NA
24 – 32 Amps	+M622	NA
29 – 42 Amps	+M623	NA

Other DCS800 documentation

This manual describes the unique features of the DCS800-EP Panel Drive. For general information about the DCS800 module, please refer to the following:

DCS800 Quick Guide	3ADW000191
DCS800 Firmware Manual	3ADW000193
DCS800 Hardware Manual (modules)	3ADW000194
DCS800 Technical Catalog	DCS800-PHTC01U-EN

Also see:

DCS800-EP Replacement Guide for FlexPak[®] 3000 DCS800-PHTG01u-EN

*See the Firmware Manual or Hardware Manual for references to other DCS800 publications.

FlexPak[®] 3000 is a registered trademark of Rockwell Automation, Inc.

Mechanical installation

Unpacking the unit

- Remove the corrugated paperboard box by removing the shipping straps and lifting the box up and off of the shipping pallet.
- Remove the wrapper, plastic and other packing material. Retain the accessory kit!
- Remove the screws holding the drive to the wood pallet.
- For frame A, the drive can be lifted. All drives have lifting holes to allow for mechanical lift.



Delivery check

- Check that there are no signs of damage.
- Before attempting installation and operation, check the information on the label of the drive to verify that the unit is of the correct size and type. A typical label is shown.

DCS800 PANEL DRIVE		Model No.	DCS800-EP1-0020-05+F278+E213+0F250+M602				UL File #E165086	
(A) 781	Amps Total	SCCR	65	KA RMS sym. @460V	Power (Pn)	(G) 600HP	450 kW	
(B) 775	A (largest motor)	Input (I1n)	(C) 775	A	Volts (U1)	230/460-3 (E)	Hz	50/60
See Hardware Manual		Output (I2n)	(D) 950	Adc	Volts (U2)	240/500dc (F)	Field (If)	6 Adc

- A Input current for entire panel
 B Input current for the drive module only
 C Drive module rated input current
 D Drive module rated output current
 E Drive module rated input voltage
 F Drive module rated output voltage
 G Drive module rated power

Requirements for installation

The drive must be installed in an upright position within a cabinet or other enclosure.

The cabinet size, heat dissipation capability and clearances must conform to the requirements below.

Refer to *Dimensional drawings* for frame details.

See *Cabinet cooling and air flow* for the allowed ambient conditions of the drive.

Minimum clearances

When installing the panel in a cabinet, minimum clearances from the panel to the cabinet walls, top and bottom must be maintained. This space is required for proper cabling, cooling air flow, service and maintenance. If one drive is mounted directly above another, see DCS800 Hardware Manual “Mechanical Installation” for additional information.

See chapter *Dimensional drawings*.

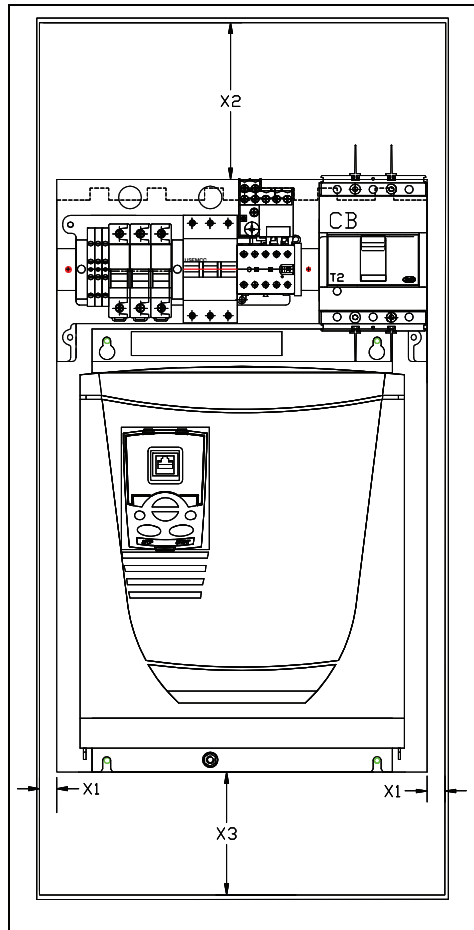

Frame	X1 (side)	X2 (top)	X3 (bottom)
A	0.5 in. (13 mm)	5.0 in. (127 mm)	4.0 in. (102 mm)
B	0.5 in. (13 mm)	10.0 in. (254 mm)	5.0 in. (127 mm)
C	0.5 in. (13 mm)	10.0 in. (254 mm)	5.0 in. (127 mm)
D	2.0 in. (51 mm)	12.0 in. (305 mm)	5.0 in. (127 mm)

Frame D Depth: Frame D drives without circuit breaker have live lugs at the highest point on the drive. Sixteen inches of cabinet depth is required plus a minimum of 1/2" air gap between lugs and cabinet door or as required by applicable codes. **REMEMBER:** door may flex inward!

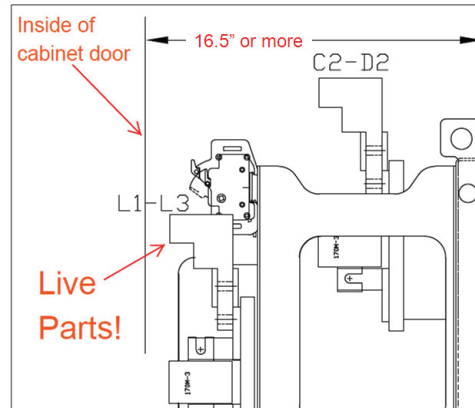

Frame D side view

Cabinet cooling and air flow

Cabinets must be sized to accommodate minimum clearances as described in the previous section and in the DCS800 Hardware Manual.

The maximum interior cabinet ambient temperature must not exceed 40°C.

See table below for heat dissipation requirements. Cooling air enters the bottom of the drive module and exits at the top (see diagram at right).

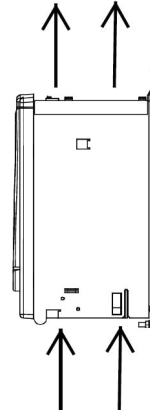

Panel heat dissipation

HP	Non-Regenerative (2Q)			Regenerative (4Q)		
	Type Code	Total panel watts loss		Type Code	Total panel watts loss	
		without inductor	with inductor		without inductor	with inductor
10	DCS800-EP1-0020-05	162	182	DCS800-EP2-0025-05	165	185
20	DCS800-EP1-0045-05	228	283	DCS800-EP2-0050-05	234	289
30	DCS800-EP1-0065-05	291	350	DCS800-EP2-0075-05	307	366
40	DCS800-EP1-0090-05	356	426	DCS800-EP2-0100-05	370	440
60	DCS800-EP1-0125-05	483	578	DCS800-EP2-0140-05	517	612
75	DCS800-EP1-0180-05	656	751			
100				DCS800-EP2-0200-05	757	884
125	DCS800-EP1-0230-05	882	1017	DCS800-EP2-0260-05	939	1074
150	DCS800-EP1-0315-05	1074	1209	DCS800-EP2-0350-05	1143	1278
200	DCS800-EP1-0405-05	1320	–	DCS800-EP2-0450-05	1342	–
250	DCS800-EP1-0470-05	1561	–	DCS800-EP2-0520-05	1594	–
300	DCS800-EP1-0610-05	1975	–	DCS800-EP2-0680-05	2002	–
400	DCS800-EP1-0740-05	2569	–	DCS800-EP2-0820-05	2569	–
500	DCS800-EP1-0900-05	3123	–	DCS800-EP2-1000-05	3108	–
600				DCS800-EP2-1010-05	3237	–

Planning the electrical installation

What this chapter contains

This chapter contains the instructions for selecting the cables, cable routing and line reactors for the drive panel. Always follow local regulations.

Note: If the recommendations given by ABB are not followed, the drive may experience problems that are not necessarily covered by the warranty.

Reference: *Technical Guide* – publ. no.: 3ADW000163

Options for the drive

Line reactors

When thyristor power converters operate, the line voltage is short-circuited during commutation from one thyristor to the next. This operation causes voltage dips in the mains PCC (point of common coupling). Some ACS800-EP Panel Drives are shipped with an internal 1.5% line reactor and some are not (as indicated by the drive's Plus Code). For the connection of a power converter system to the mains, one of the following configurations should be applied:

Configuration A

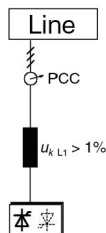

When using the power converter, a minimum of impedance is required to ensure proper performance of the snubber circuit. A line reactor can be used to meet this minimum impedance requirement. The value must therefore not drop below 1% u_k (relative impedance voltage). It should not exceed 10% u_k , due to considerable voltage drops at converter output.

Configuration B

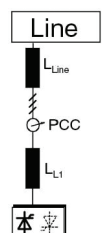

If special requirements have to be met at the PCC (standards like EN 61800-3, DC and AC drives at the same line, etc), different criteria must be applied for selecting a line reactor. These requirements are often defined as a voltage dip in percent of the nominal supply voltage. The combined impedance of $Z_{L_{Line}}$ and $Z_{L_{L1}}$ constitute the total series impedance of the installation. The ratio between the line impedance and the line reactor impedance determines the voltage dip at the connecting point. In such cases line chokes with an impedance around 4% are often used.

Example calculation with $U_{k L_{Line}}=1\%$; $U_{k L_{L1}}=4\%$; **Voltage Dip = $Z_{L_{Line}} / (Z_{L_{Line}}+Z_{L_{L1}})=20\%$** . Detailed calculation see Technical Guide.

Line reactors (cont)

Configuration C

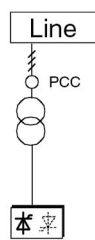

If an isolation transformer is used, it is possible to comply with certain connecting conditions per Configuration B without using an additional line reactor. The condition described in Configuration A will then likewise be satisfied, since the u_k is $>1\%$.

Configuration C1

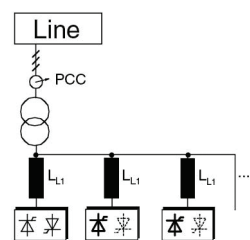

If 2 or more converters are supplied by one transformer, the final configuration depends on the number of drives in use and their power capability.

Either configuration A or B (which are based on commutation chokes) has to be used, if the drive system consists of any of the converters (D1, D2, D3, D4.)

With reference to the power converter:

The line reactors are listed in the table on page 30. They:

- have been sized to the units nominal current
- are based on a duty cycle

For further information in this publication:

See chapter *Accessories - Line reactors*.

Typical cable sizing and tightening torque

Based on U.S. NEC Table 310.16. No more than three current carrying conductors per raceway.
Maximum Ambient Temperature - 40°C, Conductor Temperature Rating - 75°C except where noted.

Drive Panel	460Vac/500Vdc			230Vac/240Vdc			AC input L1, L2, L3	DC output C2, D2	Ground PE	Tightening Torque (ft-lb)			
	HP	IAC (amps)	IDC (amps)	HP	IAC (amps)	IDC (amps)	Typical Cable	Typical Cable	Minimum Cable ①	with breaker	without breaker		
										L1-L2-L3	L1-L2-L3	C2, D2	PE
DCS800-EP1-0020-05	10	14	17	5	16	20	12 AWG ¹	10 AWG	12 AWG	35 in-lb	10	10	
DCS800-EP2-0025-05	10	14	17	5	16	20	12 AWG ¹	10 AWG	12 AWG	35-40 in-lb	10	10	
DCS800-EP1-0045-05	20	29	35	10	30	37	8 AWG	8 AWG ¹	10 AWG	45 in-lb	10	10	
DCS800-EP2-0050-05	20	29	35	10	30	37	8 AWG	8 AWG ¹	10 AWG	45 in-lb	10	10	
DCS800-EP1-0065-05	30	43	53	15	44	54	6 AWG	4 AWG	10 AWG	45-50 in-lb	10	10	
DCS800-EP2-0075-05	30	43	53	15	44	54	6 AWG	4 AWG	10 AWG	50 in-lb	10	10	
DCS800-EP1-0090-05	40	55	68	20	58	71	4 AWG	2 AWG	8 AWG	50 in-lb	10	10	
DCS800-EP2-0100-05	40	55	68	20	58	71	4 AWG	2 AWG	8 AWG	50 in-lb	10	10	
DCS800-EP1-0125-05	60	85	104	30	86	105	1 AWG	1/0 AWG	6 AWG	50 in-lb	10	10	
DCS800-EP2-0140-05	60	85	104	30	86	105	1 AWG	1/0 AWG	6 AWG	50 in-lb	10	10	
DCS800-EP1-0180-05	75	102	125	30	102	125	1/0 AWG	3/0 AWG	6 AWG	23	15	23	9
DCS800-EP2-0200-05	100	134	164	50	143	175	3/0 AWG	250 MCM	6 AWG	23	21	23	9
DCS800-EP1-0230-05	125	167	205	60	168	206	250 MCM	350 MCM	4 AWG	23	27	23	9
DCS800-EP2-0260-05	125	167	205	60	168	206	250 MCM	350 MCM	4 AWG	23	27	23	9
DCS800-EP1-0315-05	150	200	245	75	208	255	300 MCM ²	350 MCM ²	4 AWG	23	27	23	9
DCS800-EP2-0350-05	150	200	245	75	208	255	300 MCM ²	350 MCM ²	4 AWG	23	27	23	9
DCS800-EP1-0405-05	200	265	325	100	278	341	500 MCM ^{3,5}	2 x 250 MCM ⁴	2 AWG	23	23	23	31
DCS800-EP2-0450-05	200	265	325	100	278	341	500 MCM ^{3,5}	2 x 250 MCM ⁴	2 AWG	23	23	23	31
DCS800-EP1-0470-05	250	330	405	125	347	425	2 x 250 MCM ³	2 x 350 MCM ⁴	2 AWG	23	23	23	31
DCS800-EP2-0520-05	250	330	405	125	347	425	2 x 250 MCM ³	2 x 350 MCM ⁴	2 AWG	23	23	23	31
DCS800-EP1-0610-05	300	392	480	150	413	506	2 x 300 MCM ^{1,3}	2 x 500 MCM ⁴	2 AWG	23	23	23	31
DCS800-EP2-0680-05	300	392	480	150	413	506	2 x 300 MCM ^{1,3}	2 x 500 MCM ⁴	2 AWG	23	23	23	31
DCS800-EP1-0740-05	400	522	640	NA			2 x 500 MCM	3 x 350 MCM	1/0 AWG	31	42	42	31
DCS800-EP2-0820-05	400	522	640				2 x 500 MCM	3 x 350 MCM	1/0 AWG	31	42	42	31
DCS800-EP1-0900-05	500	649	795				3 x 350 MCM	3 x 500 MCM	2/0 AWG	31	42	42	31
DCS800-EP2-1000-05	500	649	795				3 x 350 MCM	3 x 500 MCM	2/0 AWG	31	42	42	31
DCS800-EP2-1010-05	600	775	950				3 x 350 MCM	4 x 500 MCM	2/0 AWG	31	42	42	31

¹ For 230V, use one size larger cable diameter

² Use 90°C wire

³ Unless Circuit Breaker option is selected, connecting cables require copper compression lugs with closed holes to fit the drive's 10mm bolts (2 per terminal).

⁴ Connecting cables require copper compression lugs with closed hole to fit the drive's 10mm bolt (2 per terminal).

⁵ For 230V, use (2) 250 MCM

For drives requiring compression lugs, use these Ilco lugs or equivalents as shown below. Compression lugs to be installed according to the manufacture's requirements.

Cable Size	Recommended Lug
250 MCM	CRA-250
300 MCM	CRA-300
350 MCM	CRA-350
500 MCM	CRA-500-12

NOTE: Cable size recommendations in this manual are different from what is shown in the DCS800 Hardware Manual. For DS800-EP, these recommendations should be followed. Wire sizing in the DCS800 Hardware Manual is at Continuous Duty ratings and in this manual, Heavy Duty ratings. At Heavy Duty ratings, the drive's nominal current is lower due to derating so smaller wire could possibly be used.

① The minimum ground cable recommendation assumes that the overcurrent protection for each drive is selected to provide protection at 125% of the rated drive input current. If the overcurrent protection (e.g. circuit breaker) is sized larger than this, then larger ground cables will need to be determined manually.

Electrical installation

What this chapter contains

This chapter describes the electrical installation procedure of the drive.



WARNING! The work described in this chapter may only be carried out by a qualified electrician. Follow the *Safety instructions* on the first pages of this manual. Ignoring the safety instructions can cause injury or death.

Make sure that the drive is disconnected from the mains (input power) during installation. If the drive was already connected to the mains, wait for 5 min. after disconnecting mains power.

Reference: *Technical Guide* - publ. no.: 3ADW000163

Checking the insulation of the assembly

Each drive is factory tested for insulation between the main circuit and the chassis (2500 V rms 50 Hz for 1 second). DO NOT make any voltage tolerance or insulation resistance tests (e.g. hi-pot or megger) on any part of the drive or drive damage will occur. Check the insulation of the assembly as follows.



WARNING! Check the insulation before connecting the drive to the mains. Make sure that the drive is disconnected from the mains (input power).

1. Check that the motor cable is disconnected from the drive output terminals C2, D2, F+ and F-.
 2. Measure the insulation resistances of the motor cable and the motor between each circuit (C2, D2) or (F+, F-) and the Protective Earth by using a measuring voltage of 1 kV DC. The insulation resistance must be higher than 1 Mohm.
-

IT (ungrounded) systems

Don't use EMC filters.

The screen winding of dedicated transformers must be grounded.

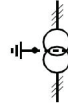

For installation without low voltage switch (e.g. contactor, air-circuit-breaker) use overvoltage protection.

The voltage shift of isolated supply must be limited of a range of an earth fault.

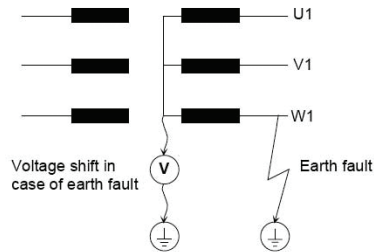

Check supply voltages

- Aux X99
- Fan Terminals
- AC voltage for armature circuit U1, V1, W1

Connecting the power cables

Grounding and screening of power cables see manual *Technical Guide*, see *Reference*.

Cross sectional areas and tightening torques of power cable see chapter *Planning the electrical installation*.

Power/control connections

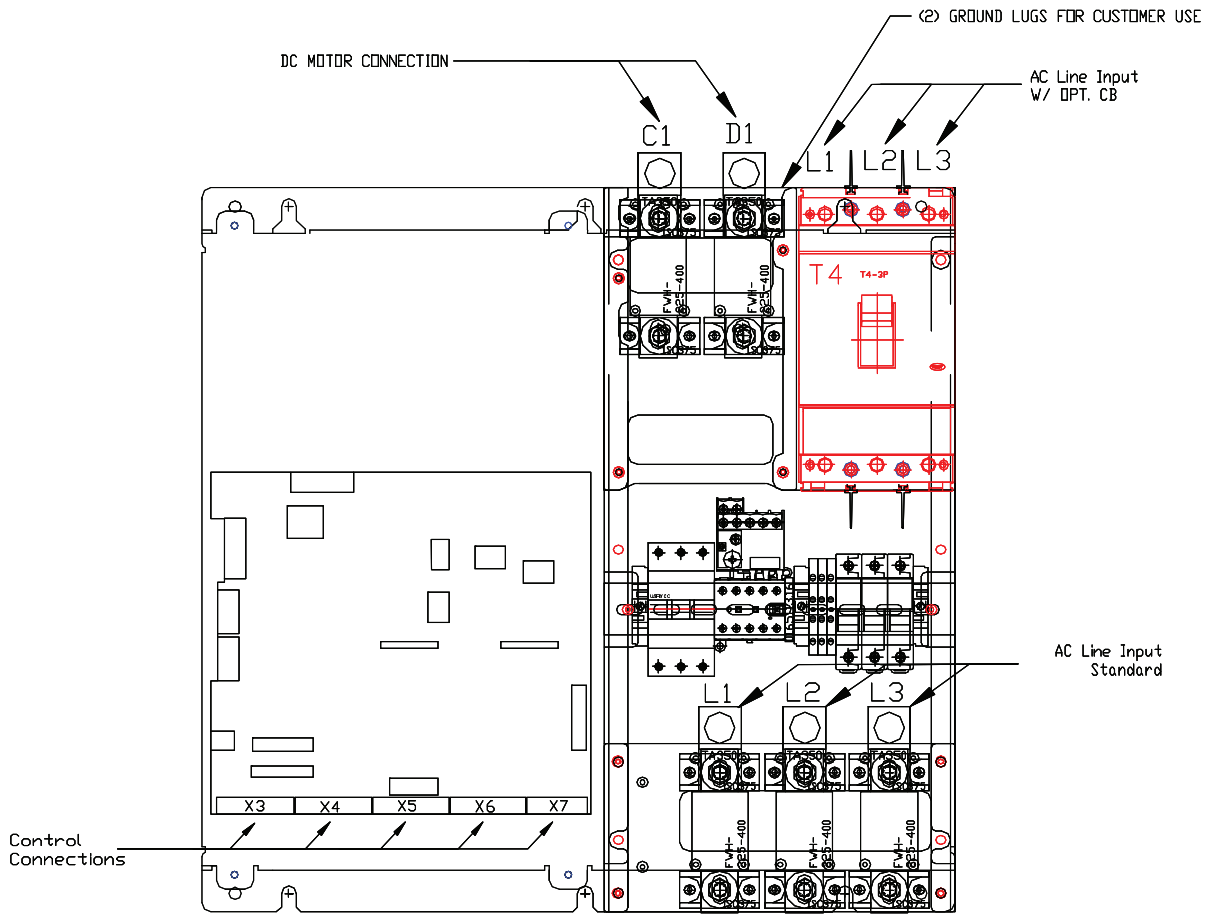

Typical location for input and output terminals.

Connection diagram

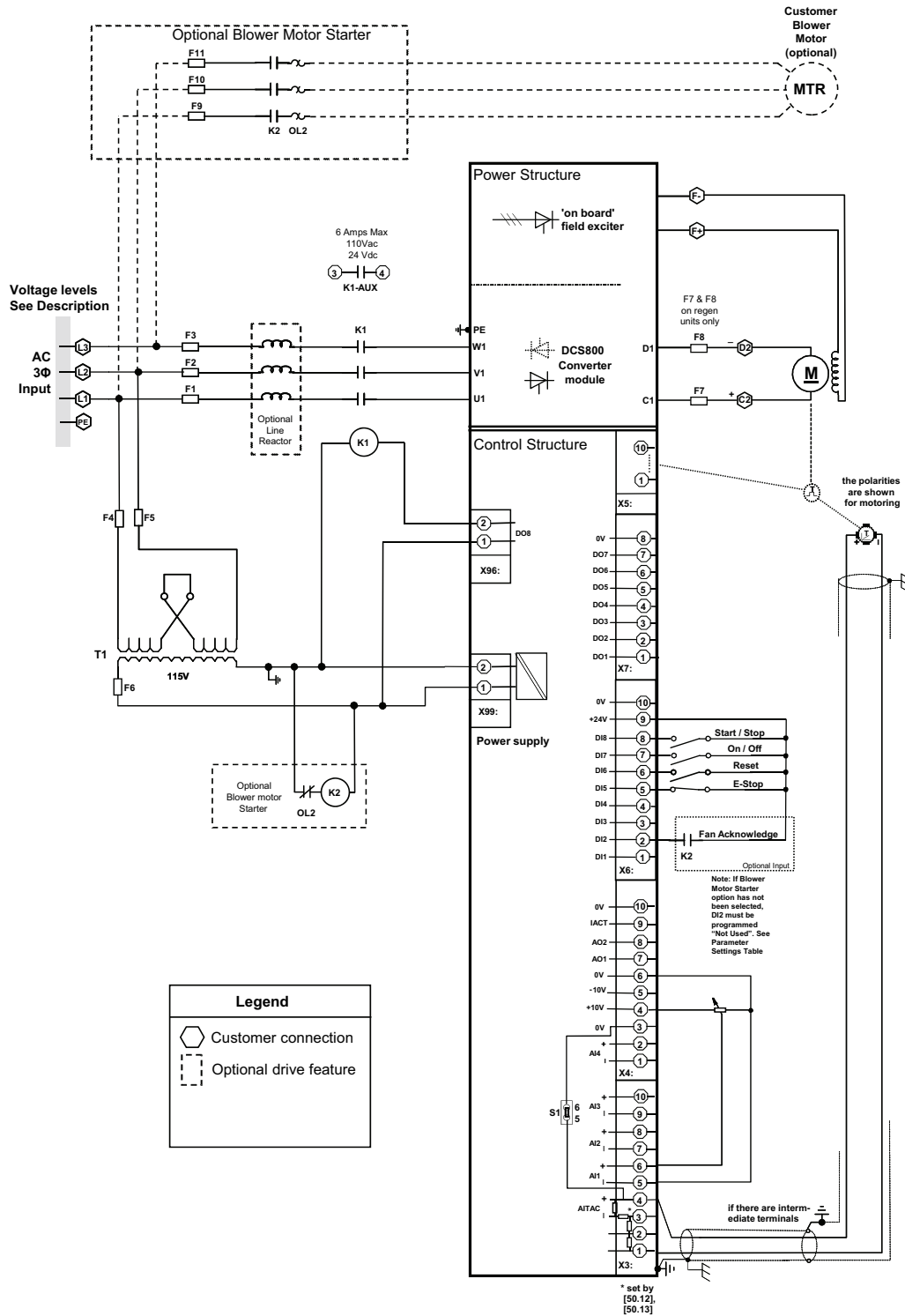

Control circuit connections

DCS800-EP drives are shipped with Factory Default parameter settings except as shown in the table below. Motor on/off control is configured for 2-wire (maintained input) control.

For parameter settings matching the FlexPak 3000, see ABB document:

DCS800-PHTG01u-EN

Replacement Guide, DCS800-EP replaces the Reliance FlexPak® 3000.

Parameter settings for I/O

Digital Inputs

Input	Factory Default	Function	Parameter	Setting	Notes
1		Unused	10.20	NOT USED	
2		Fan Acknowledge	10.06	DI2	Change to “not used” if optional blower motor starter is not selected.
3		Unused	10.21	NOT USED	
4		Unused	10.08	NOT USED	
5	✓	E-Stop	10.09	DI5	
6	✓	Reset	10.03	DI6	
7	✓	On / Off	10.15	DI7	
8	✓	Start / Stop	10.16	DI8	

NOTE: Setting “On / Off” will command the drive to close the contactor and enable the SCRs to fire at a neutral setting. When “Start / Stop” is set, the motor will accelerate to the reference speed.

Analog Inputs

Input	Function	Parameter	Setting	Notes
AI1	Speed Reference	11.03 13.01 13.02 13.03	Dependent on type of reference input	See 5.03 for actual AI1 value

Reliance Electric® and FlexPak® 3000 are registered trademarks of Rockwell Automation, Inc.

Alternate line voltage (converting to 230 Vac line)

Drive panels as received from the factory, except if "+S235" is in the type code (see page 10), are wired for an input voltage of 460 V, 60 Hz. If the ac input line voltage is to be 230 Vac, modifications must be made.



230/460 Vac rated drives can be configured for either 230 or 460 Vac input power. Before applying power, it is required to verify the control transformer configuration matches the incoming power. This is done by checking the jumpers on the "H" side of the transformer or by following the test procedure shown below. Failure to follow this precaution could result in severe damage.

DCS800-EPx-020-05 thru DCS800-EPx-0680-05

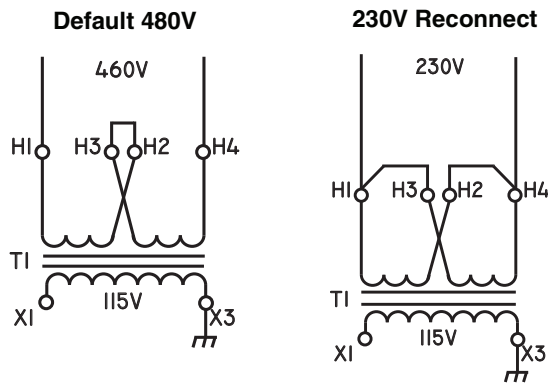

Input Power	F4 and F5 Fuses
DCS800-EPx-350-05 and below	
230 Vac input	Use (2) FNQR 2
460 Vac input	Use (2) FNQR 1-1/8
DCS800-EPx-405-05 and above	
230 Vac input	Use (2) FNQR 3
460 Vac input	Use (2) FNQR 2

230 Vac Modification Procedure

1. Disconnect and lock out all incoming power to the drive.
2. Locate the control transformer. For panel frame A, drive module must be removed to gain access. (Carefully unplug green connectors X3 - X7 first.) For panel frame B, transformer is located below line fuses. For frame C, the transformer is in plain view.
3. Remove the jumper between H2 and H3.
4. Reconnect new jumpers between H1 and H3 and between H2 and H4. Remount and reconnect the drive (frame A).
5. Remove and replace the primary fuses F4 and F5 with fuses shown in the table above.

Live Test Procedure

1. Open the F6 fuse holder to disconnect control power to the drive and blower motor starter (if present).
2. Connect 3-phase power and close disconnect 1MCB.
3. Measure voltage between fuse F6 and Terminal 2. If not 110 to 120 Vac, disconnect 3-phase power and open disconnect 1MCB. Reconfigure control transformer jumpers. Repeat live test.
4. Close the F6 fuse holder. Control power to the drive should then be connected. Control Panel will light up.
5. The drive module itself must be reprogrammed for 230 Vac input by adjusting parameter 99.10 (Nominal AC mains voltage) to a value of "230."

Installation checklist

Check the mechanical and electrical installation of the drive before start-up. Go through the checklist below together with another person. Read the *Safety instructions* on the first pages of this manual before you work on the unit.

Check

Mechanical Installation

- The cabinet internal ambient temperature and the external ambient air temperature are within limits (See Mechanical installation and Technical data).
- The cabinet is vertically mounted on a non-flammable surface.
- The cooling air can flow freely.
- The motor and the driven equipment are ready for start. (See Planning the electrical installation)
- All shield and grounding connections are properly tightened.
- All cable connections are seated properly and tightened according to specified torque. (See Typical cable sizing and tightening torque)

Electrical Installation

(See Planning the electrical installation, Electrical installation)

- The drive is properly grounded.
 - The AC input voltage matches the drive nominal input voltage.
 - The AC input cables are properly seated and tightened to specified torque. (See Typical cable sizing and tightening torque)
 - The motor cables (C1, D1 and F+, F-) are properly seated and tightened to specified torque. (See Typical cable sizing and tightening torque)
 - Proper function of the E-Stop circuitry.
 - Fan power wiring is connected.
 - Control connections are properly made and logic is sound.
 - There are no tools, foreign objects, dust or debris from drilling inside the drive.
 - Covers are in place on the drive, motor and any connection boxes.
-

Dimensions and weight

Dimensional and weight data

As Built

DCS800-EP Panel Drive						
HP at 460 Vac	Weight - no reactor lb. (kg)	Weight - with reactor lb. (kg)	Frame Size	Height in. (mm)	Width in. (mm)	Depth in. (mm)
10	54 (25)	61 (28)	A	18.79 (477)	12.15 (309)	14.40 (366)
20	57 (26)	65 (30)				
30	59 (27)	67 (30)				
40	62 (28)	73 (33)				
60	62 (28)	88 (40)				
75	95 (43)	128 (58)	B	19.29 (490)	20.00 (508)	13.82* (351)
100	103 (47)	157 (71)				
125	103 (47)	163 (74)				
150	130 (59)	185 (84)				
200	231 (105)	na	C	35.32 (897)	23.58 (599)	16.17 (411)
250	231 (105)	na				
300	260 (118)	na				
400	355 (161)	na				
500	355 (161)	na	D	45.66 (1160)	26.68 (678)	16.65 (499) / 19.65 (499)**
600	355 (161)	na				

*19.32 inch depth when internal reactor option is included

**Depth without circuit breaker option / depth with circuit breaker option

As Shipped

DCS800-EP Panel Drive						
HP at 460 Vac	Weight - no reactor lb. (kg)	Weight - with reactor lb. (kg)	Frame Size	Height in. (mm)	Width in. (mm)	Depth in. (mm)
10	63 (29)	32 (15)	A	28 (711)	31 (787)	31 (787)
20	66 (30)	34 (15)				
30	68 (31)	35 (16)				
40	71 (32)	37 (17)				
60	71 (32)	44 (20)				
75	104 (47)	62 (28)	B	28 (711)	31 (787)	31 (787)
100	112 (51)	75 (34)				
125	112 (51)	78 (35)				
150	139 (63)	88 (40)				
200	247 (112)	na	C	28 (711)	55 (1397)	31 (787)
250	247 (112)	na				
300	276 (125)	na				
400	371 (169)	na	D	28 (711)	55 (1397)	31 (787)
500	371 (169)	na				
600	371 (169)	na				

Dimensional drawings

Frame A

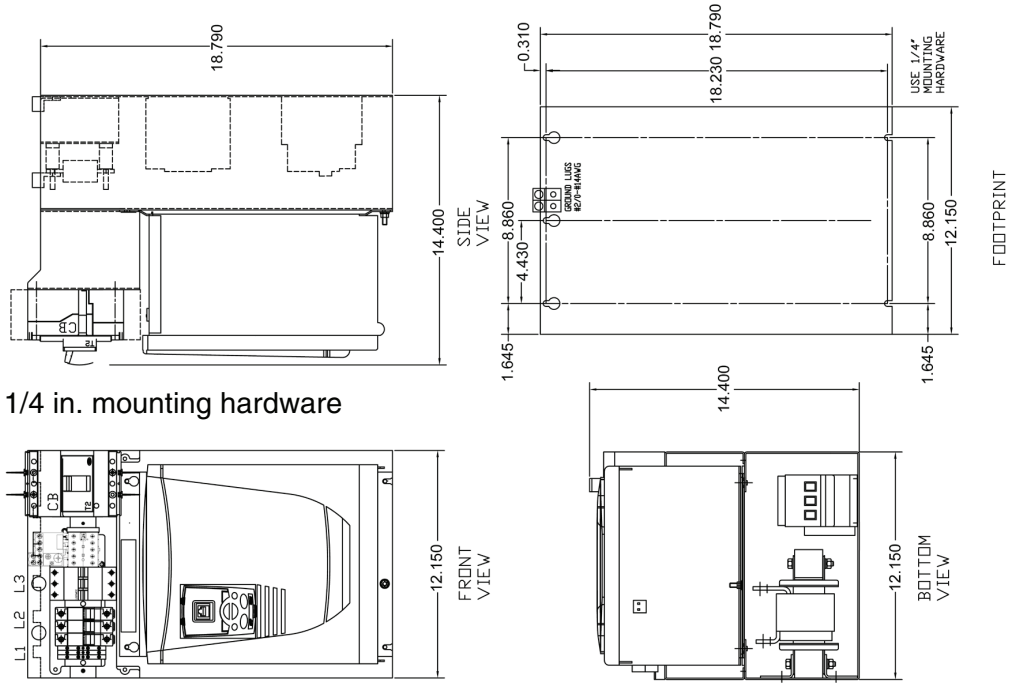

Use M6 or 1/4 in. mounting hardware

Frame B

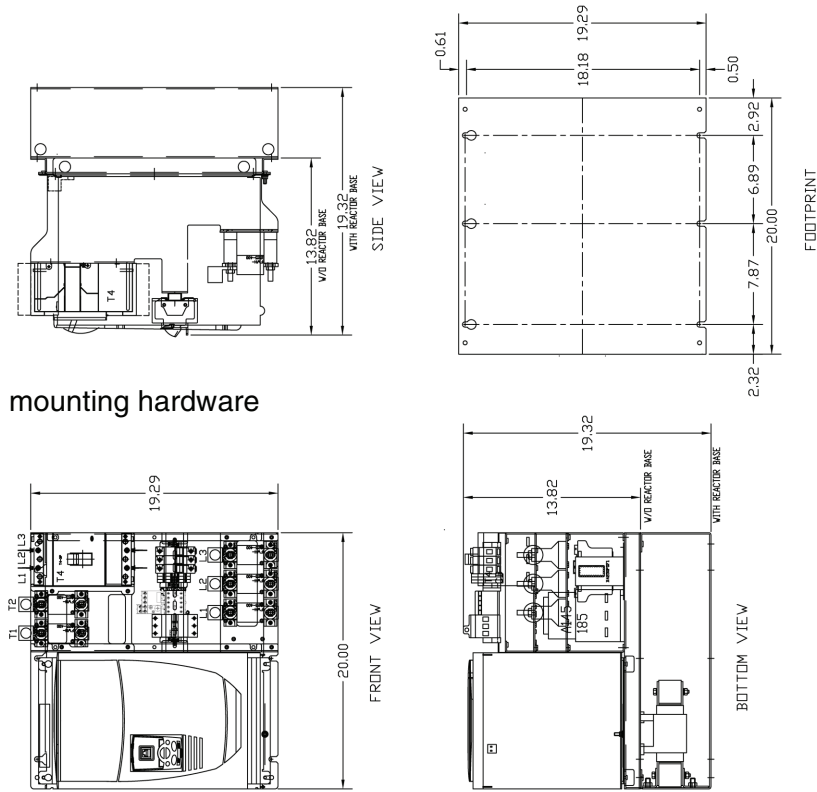

Use M8 or 5/16 in. mounting hardware

Frame C

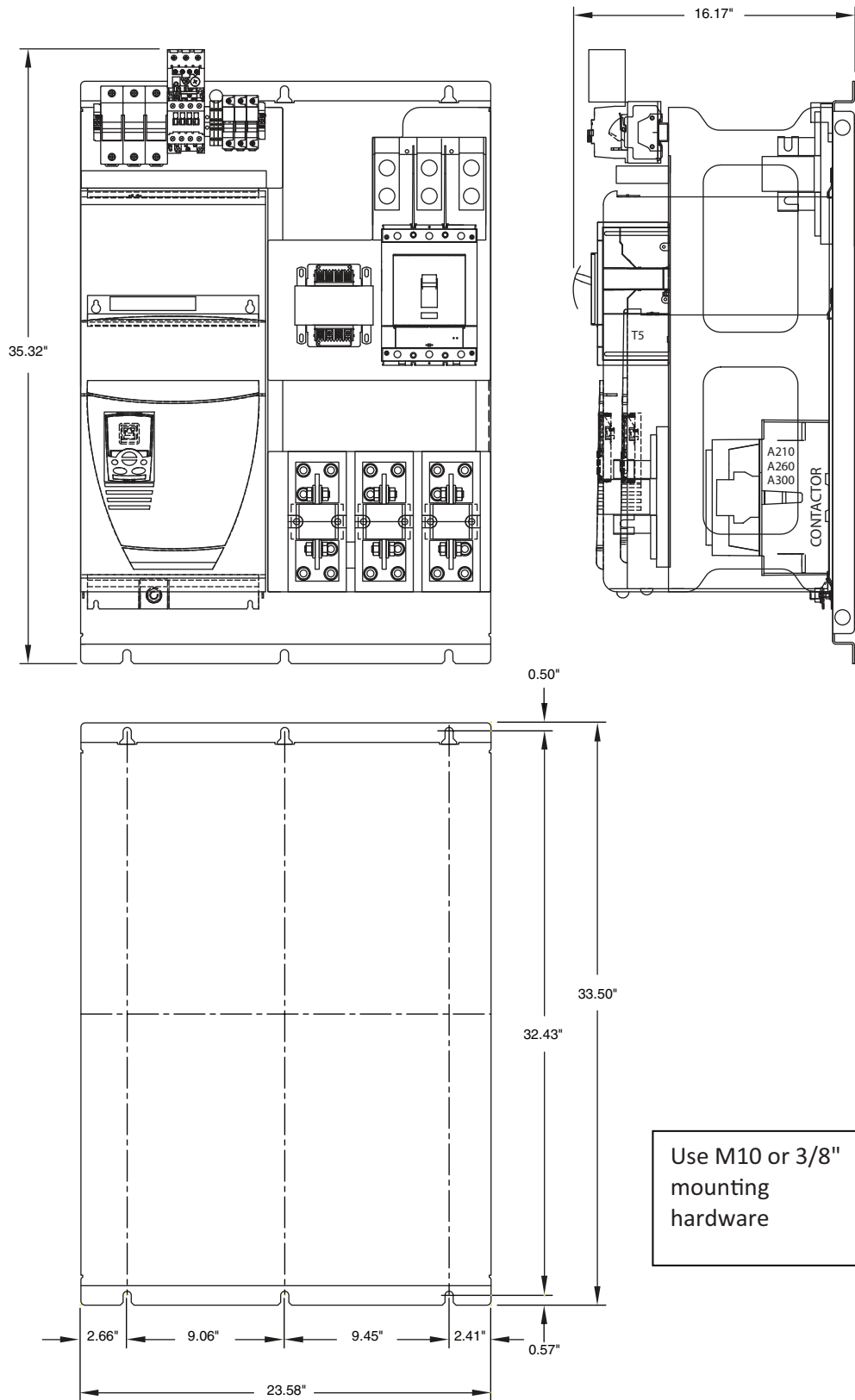

Frame D – without circuit breaker option

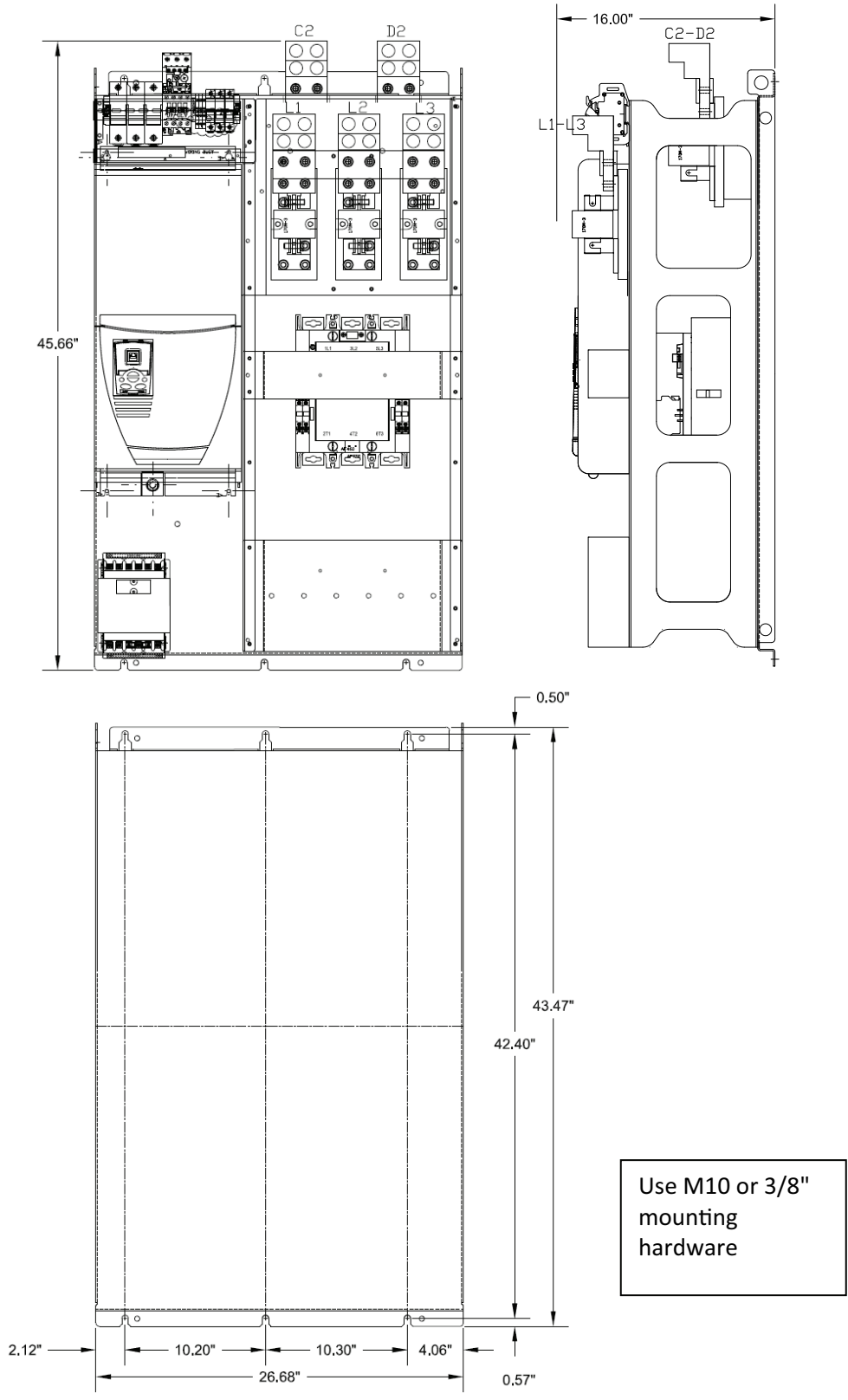

Frame D – with circuit breaker option

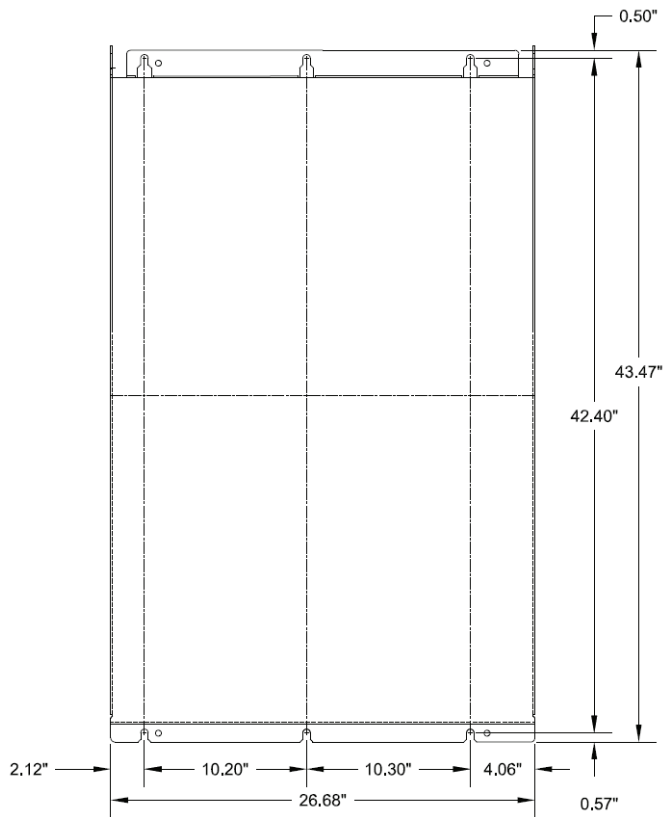
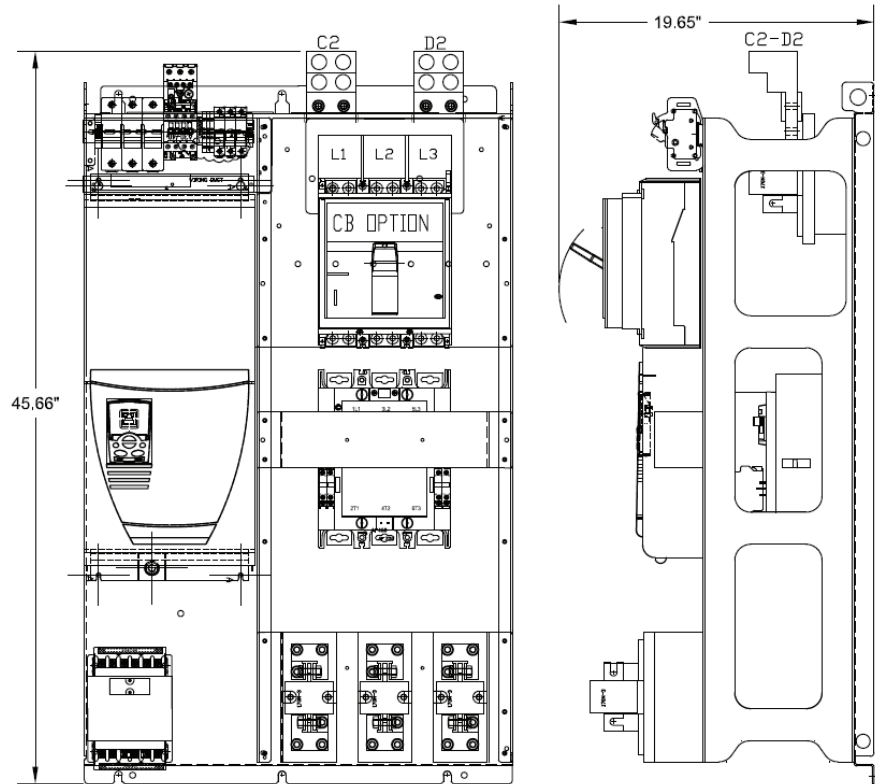

Use M10 or 3/8"
mounting
hardware

Replacement parts

Fuses

Panel Drive Non-Regenerative Regenerative	Frame	Fuse				
		AC in (module) F1, F2, F3	Control Xfmr primary F4, F5 (2 Req'd)	Control Xfmr secondary F6	DC Out (motor) F7, F8, (2 Req'd)	AC in (Blower motor starter) F9, F10, F11
Manufacturer		Bussmann	Bussmann	Bussmann	Bussmann	Bussmann
DCS800-EP1-0020-05 DCS800-EP2-0025-05	A	FWH-50B	For 480 Vac input voltage: FNQR-1-1/8 For 230 Vac input voltage FNQR-2	FNM-2-8/10	FWH-50B	See Table next page
DCS800-EP1-0045-05 DCS800-EP2-0050-05	A	FWH-80B		FNM-2-8/10	FWH-80B	
DCS800-EP1-0065-05 DCS800-EP2-0075-05	A	FWH-80B		FNM-2-8/10	FWH-80B	
DCS800-EP1-0090-05 DCS800-EP2-0100-05	A	FWH-125B		FNM-2-8/10	FWH-125B	
DCS800-EP1-0125-05 DCS800-EP2-0140-05	A	FWH-125B		FNM-2-8/10	FWH-125B	
DCS800-EP1-0180-05 -	B	FWH-200B		FNM-2-8/10	FWH-200B	
- DCS800-EP2-0200-05	B	FWH-200B		FNM-2-8/10	FWH-200B	
DCS800-EP1-0230-05 DCS800-EP2-0260-05	B	FWH-250A		FNM-2-8/10	FWH-250A	
DCS800-EP1-0315-05 DCS800-EP2-0350-05	B	FWH-300A		FNM-2-8/10	FWH-300A	
DCS800-EP1-0405-05 DCS800-EP2-0450-05	C	170M6011		For 480 Vac input voltage: FNQR-2	FNM-4	
DCS800-EP1-0470-05 DCS800-EP2-0520-05	C	170M6011	For 230 Vac input voltage: FNQR-3	FNM-4	170M6011	
DCS800-EP1-0610-05 DCS800-EP2-0680-05	C	170M6013	FNQR-3	FNM-4	170M6013	
DCS800-EP1-0740-05 DCS800-EP2-0820-05	D	170M6013	FNQR-3	FNM-8	170M6013	
DCS800-EP1-0900-05 DCS800-EP2-1000-05	D	170M6015	FNQR-3	FNM-8	170M6015	
- DCS800-EP2-1010-05	D	170M6016	FNQR-3	FNM-8	170M6016	

Fuse tightening torque for AC in (F1 – F3) and DC out (F7 – F8) fuses

HP at 460V	Frame Size	Tightening Torque ft-lb (Nm)	Bolt Size
10 - 60	A	5 (7)	1/4"-20
75 - 150	B	16 (22)	3/8"-16
200 - 300	C	15 (20)	M10
400 - 600	D	15 (20)	M10

Blower motor starter

Plus Code	Blower HP 460Vac	Blower HP 230Vac	Blower Amps 460V/230V	Fuses F9, F10, F11	Contactor	Overload
				Bussmann	ABB	ABB
+M635	1/2	-	1.1	LP-CC-2	Mini contactor 120 Vac coil B7-30-10-84	T16-1.3
+M636	3/4	-	1.6	LP-CC-3.2		T16-1.7
+M637	1	1/2	2.1/2.2	LP-CC-4		T16-2.3
+M638	1.5	-	3.0	LP-CC-6		T16-3.1
+M639	2	3/4	3.4/3.2	LP-CC-6		T16-4.2
+M640	3	1	4.8/4.2	LP-CC-10		T16-5.7
+M641	-	1-1/2	6	LP-CC-10		T16-7.6
+M641	-	2	6.8	LP-CC-10		T16-7.6
+M641	5	-	7.6	LP-CC-15		T16-7.6
+M611	3/4	-	1.6	LPJ-3-2/10-SP		ABB contactor 120V coil A26-30-10-84
+M612	1	-	2.1	LPJ-4SP	TA25DU2.1-20	
+M613	1.5	-	3.0	LPJ-6SP	TA25DU3.1-20	
+M614	2	3/4	3.4/3.2	LPJ-6SP	TA25DU4.0-20	
+M615	3	1	4.8/4.2	LPJ-8SP	TA25DU5.0-20	
+M616	-	1-1/2	6	LPJ-10SP	TA25DU6.5-20	
+M617	5	2	7.6/6.8	LPJ-15SP	TA25DU8.5-20	
+M618	7.5	3	11/9.6	LPJ-20SP	TA25DU11-20	
+M619	10		14	LPJ-20SP	TA25DU14-20	
+M620		5	15.2	LPJ-25SP	TA25DU19-20	
+M621	15	7.5	21/22	LPJ-30SP	TA25DU25-20	
+M622	20	10	27/28	LPJ-40SP	TA25DU32-20	
+M623	25 - 30	15	34 - 40/42	LPJ-60SP	A40-30-10-84	

Other replacement parts

Panel Drive Non-Regenerative Regenerative	Frame	AC Input Contactor K1 (1)	Control Transformer T1 (1)	Circuit Breaker 1MCB (1)	Line Reactor (1)
Manufacturer		ABB	Micron	ABB	TCI
DCS800-EP1-0020-05 DCS800-EP2-0025-05	A	A16-30-10-84	1B250BTZ13JKF	T2H025E5W	KLR16BTB
DCS800-EP1-0045-05 DCS800-EP2-0050-05	A	A26-30-10-84	1B250BTZ13JKF	T2H060E5W	KLR35BTB
DCS800-EP1-0065-05 DCS800-EP2-0075-05	A	A40-30-10-84	1B250BTZ13JKF	T2H060E5W	KLR45BTB
DCS800-EP1-0090-05 DCS800-EP2-0100-05	A	A50-30-11-84	1B250BTZ13JKF	T2H100E5W	KLR55BCB
DCS800-EP1-0125-05 DCS800-EP2-0140-05	A	A75-30-11-84	1B250BTZ13JKF	T2HQ100BW	KLR110BCB
DCS800-EP1-0180-05 -	B	A95-30-11-84	1B250BTZ13JKF	T4H150E5W	KLR110BCB
- DCS800-EP2-0200-05	B	A145-30-11-84	1B250BTZ13JKF	T4H250E5W	KLR160BCB
DCS800-EP1-0230-05 DCS800-EP2-0260-05	B	A145-30-11-84	1B250BTZ13JKF	T4H250E5W	KLR200BCB
DCS800-EP1-0315-05 DCS800-EP2-0350-05	B	A145-30-11-84	1B250BTZ13JKF	T4H250E5W	KLR200BCB
DCS800-EP1-0405-05 DCS800-EP2-0450-05	C	A260-30-11-84	B350BTZ13JKF	T5H400E5W	KLR300BCB
DCS800-EP1-0470-05 DCS800-EP2-0520-05	C	A300-30-11-84	B350BTZ13JKF	T5H600E5W	KLR360BCB
DCS800-EP1-0610-05 DCS800-EP2-0680-05	C	A300-30-11-84	B350BTZ13JKF	T5H600E5W	KLR420BCB
DCS800-EP1-0740-05 DCS800-EP2-0820-05	D	AF460-30-11-70	B750BTZ13JKF	T6H800E5W	KLR600BCB
DCS800-EP1-0900-05 DCS800-EP2-1000-05	D	AF580-30-11-70	B750BTZ13JKF	T7H1200E5W	KLR750BCB
- DCS800-EP2-1010-05	D	AF750-30-11-70	B750BTZ13JKF	T7H1200E5W	KLR850BCB

Technical data

Electrical and environmental data

Specification	Permitted Value
Electrical	
Input Voltage, 3-Phase	230 / 460 Vac
Input voltage deviation	±10% continuous, ±15% short time
Note: Special consideration must be given to voltage deviation in regeneration mode.	
Rated Frequency	50 Hz. or 60 Hz. ±2%
Environmental	
Cabinet internal ambient temperature	0 to 40°C
Change of ambient temperature	< 0.5°C
Relative humidity	5% to 95%, non-condensing
Site altitude	< 1000 m above sea level at 100% current > 1000 m above sea level at reduced current
Storage temperature	-40 to +55°C
Transportation temperature	-40 to +70°C

Reference DSC800 Hardware Manual *Technical Data*

Specifications

Environmental

Cabinet internal ambient temperature: 0 to 40 C
Protection Class: UL Type Open / IP00

Overload

150 pct of rated current for 60 seconds followed by 15 minutes at rated current or below

NOTE: Cannot be rerated for higher continuous current since all system components are sized based on these ratings

Input reactance

1.5 pct impedance when optional line reactor is included (available up to 150 hp)

NOTE: All drives require line reactor or dedicated isolation transformer with input impedance of 1.5 pct min; 4 to 10 pct max depending on system configuration. See "Line Reactors" in DCS800 Hardware Manual for details.

Fuse Protection

AC input line fuses (3)
DC output armature fuses, regen only (2)

Circuit breaker Protection (optional)

Instantaneous trip:

All Drives: Factory set at 300 pct of rated current

Thermal overload trip:

60 HP (DCS800-EP1-0125-05 and DCS800-EP2-0140-05) only: Factory set to 100 pct of rated current

Control transformer

230/460 Vac primary; 120 Vac secondary

Unit Type (2 Quadrant)	Unit Type (4 Quadrant)	460V Motor HP	Capacity (VA)	Capacity @ 115V (Amps)	Drive Load (Amps)	Blower Starter Load (Amps)	- Available -		
							no Starter (Amps)	with Starter (Amps)	
DCS800-S01-0020-05	DCS800-S02-0025-05	10	250	2.17	1.46	0.03	0.71	0.68	
DCS800-S01-0045-05	DCS800-S02-0050-05	20			1.49		0.68	0.65	
DCS800-S01-0065-05	DCS800-S02-0075-05	30			1.49		0.68	0.65	
DCS800-S01-0090-05	DCS800-S02-0100-05	40			1.55		0.63	0.60	
DCS800-S01-0125-05	DCS800-S02-0140-05	60			1.55		0.63	0.60	
DCS800-S01-0180-05	—	75			1.62		0.56	0.53	
—	DCS800-S02-0200-05	100			1.74		0.44	0.41	
DCS800-S01-0230-05	DCS800-S02-0260-05	125			1.74		0.44	0.41	
DCS800-S01-0315-05	DCS800-S02-0350-05	150			1.74		0.44	0.41	
DCS800-S01-0405-05	DCS800-S02-0450-05	200	350	3.04	2.3	0.11	0.75	0.64	
DCS800-S01-0470-05	DCS800-S02-0520-05	250			2.3		0.75	0.64	
DCS800-S01-0610-05+S171	DCS800-S02-0680-05+S171	300			1.85		1.19	1.08	
DCS800-S01-0740-05+S171	DCS800-S02-0820-05+S171	400	750	6.52	1.85			4.67	4.56
DCS800-S01-0900-05+S171	DCS800-S02-1000-05+S171	500			2.59			3.93	3.82
—	DCS800-S02-1010-05+S171	600			2.59			3.93	3.82

AC Contactor

AC line contactor with (1) aux. N.O. contact for customer use: 6 Amps @ 24 – 127 Vac or 24 Vdc

Blower Motor Starter Thermal Overload Relay

I_{nom} : Factory set to minimum rating. Must be field adjusted to actual blower motor nominal current.

RESET: Factory set to MANUAL

RESET/STOP: Factory set to “R” (RESET)

See Appendix 1 for installation instructions.

Accessories

Line reactors

External Line Reactors								
Non-Regenerative (2Q)	Regenerative (4Q)	HP	Line Reactor for Configuration A			Line Reactor for Configuration B		
			Manufactured by TCI					
			1.5% impedance	Watts Loss	Weight (Lbs.)	5% impedance	Watts Loss	Weight (Lbs.)
DCS800-EP1-0020-05	DCS800-EP2-0025-05	10	KLR16BTB	20	7	KLR16CTB	58	12
DCS800-EP1-0045-05	DCS800-EP2-0050-05	20	KLR35BTB	55	8	KLR35CTB	97	22
DCS800-EP1-0065-05	DCS800-EP2-0075-05	30	KLR45BTB	59	8	KLR45CTB	118	24
DCS800-EP1-0090-05	DCS800-EP2-0100-05	40	KLR55BTB	70	11	KLR55CTB	150	32
DCS800-EP1-0125-05	DCS800-EP2-0140-05	60	KLR110BCB	95	26	KLR110CCB	191	50
DCS800-EP1-0180-05	–	75	KLR110BCB	95	26	KLR110CCB	191	50
–	DCS800-EP2-0200-05	100	KLR160BCB	127	47	KLR160CCB	254	84
DCS800-EP1-0230-05	DCS800-EP2-0260-05	125	KLR200BCB	135	53	KLR200CCB	337	110
DCS800-EP1-0315-05	DCS800-EP2-0350-05	150	KLR200BCB	135	53	KLR200CCB	337	110
DCS800-EP1-0405-05	DCS800-EP2-0450-05	200	KLR300BCB	216	54	KLR300CCB	443	122
DCS800-EP1-0470-05	DCS800-EP2-0520-05	250	KLR360BCB	221	65	KLR360CCB	406	156
DCS800-EP1-0610-05	DCS800-EP2-0680-05	300	KLR420BCB	275	85	KLR420CCB	500	160
DCS800-EP1-0740-05	DCS800-EP2-0820-05	400	KLR600BCB	338	96	KLR600CCB	650	275
DCS800-EP1-0900-05	DCS800-EP2-1000-05	500	KLR750BCB	372	147	KLR750CCB	732	295
–	DCS800-EP2-1010-05	600	KLR850BCB	389	150	KLR850CCB	850	300

Diagrams

Power diagram

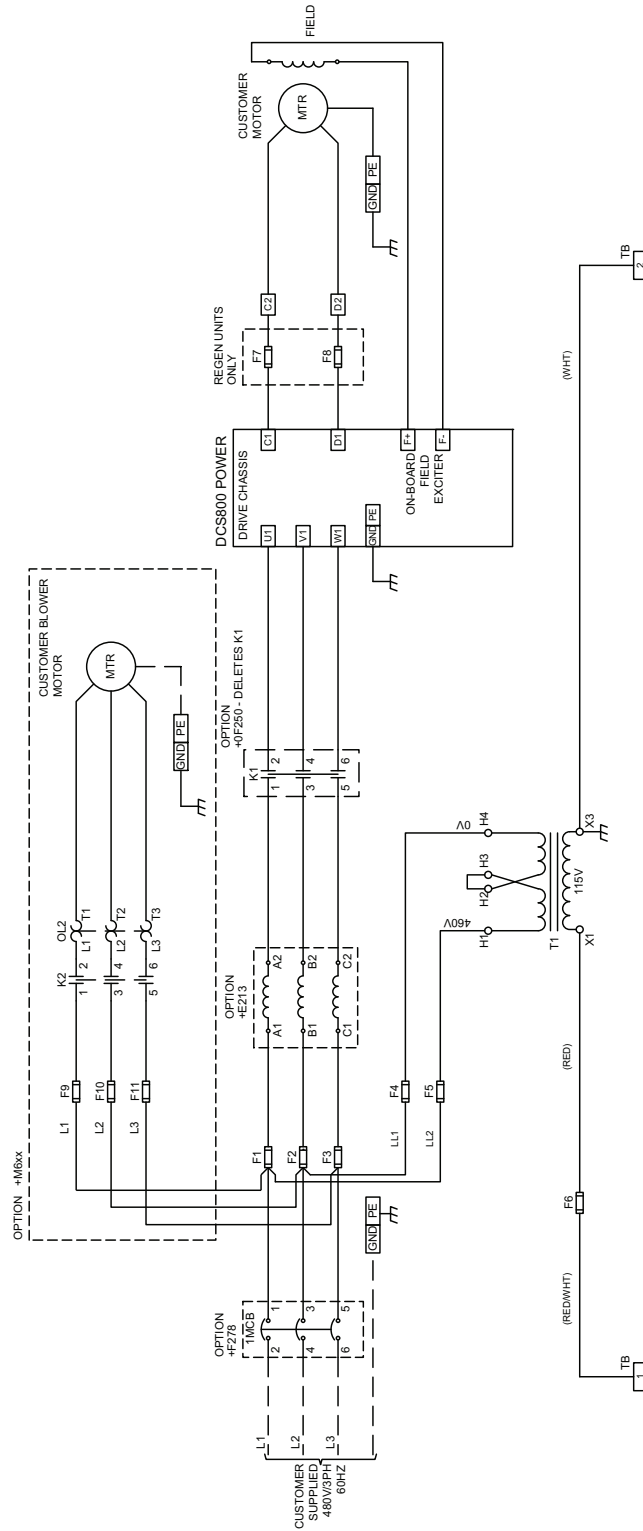

Control diagram

Control Diagram C1 – 10 to 250 hp (DCS800-EP1-0020 through EP2-0520)

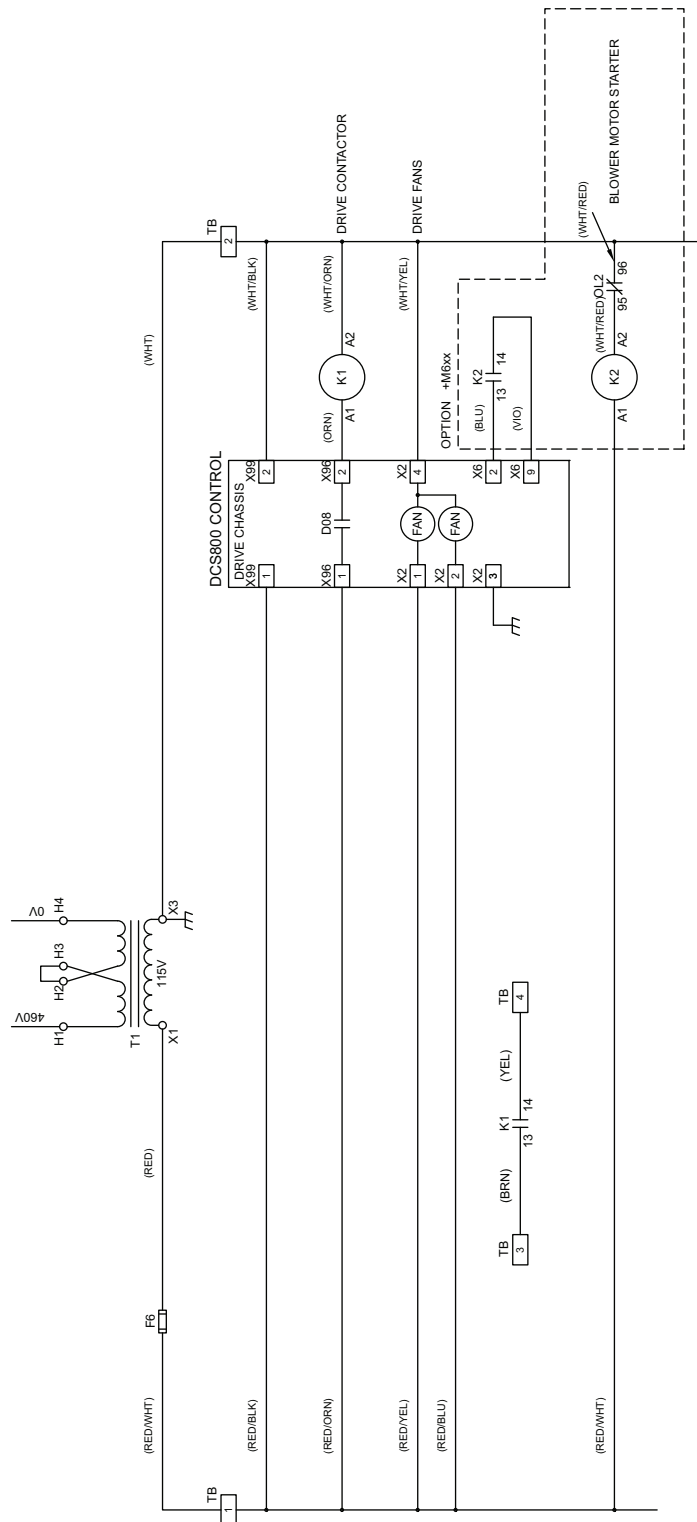

Control Diagram C2 – 300 to 600 hp (DCS800-EP1-0610 through EP2-1010)

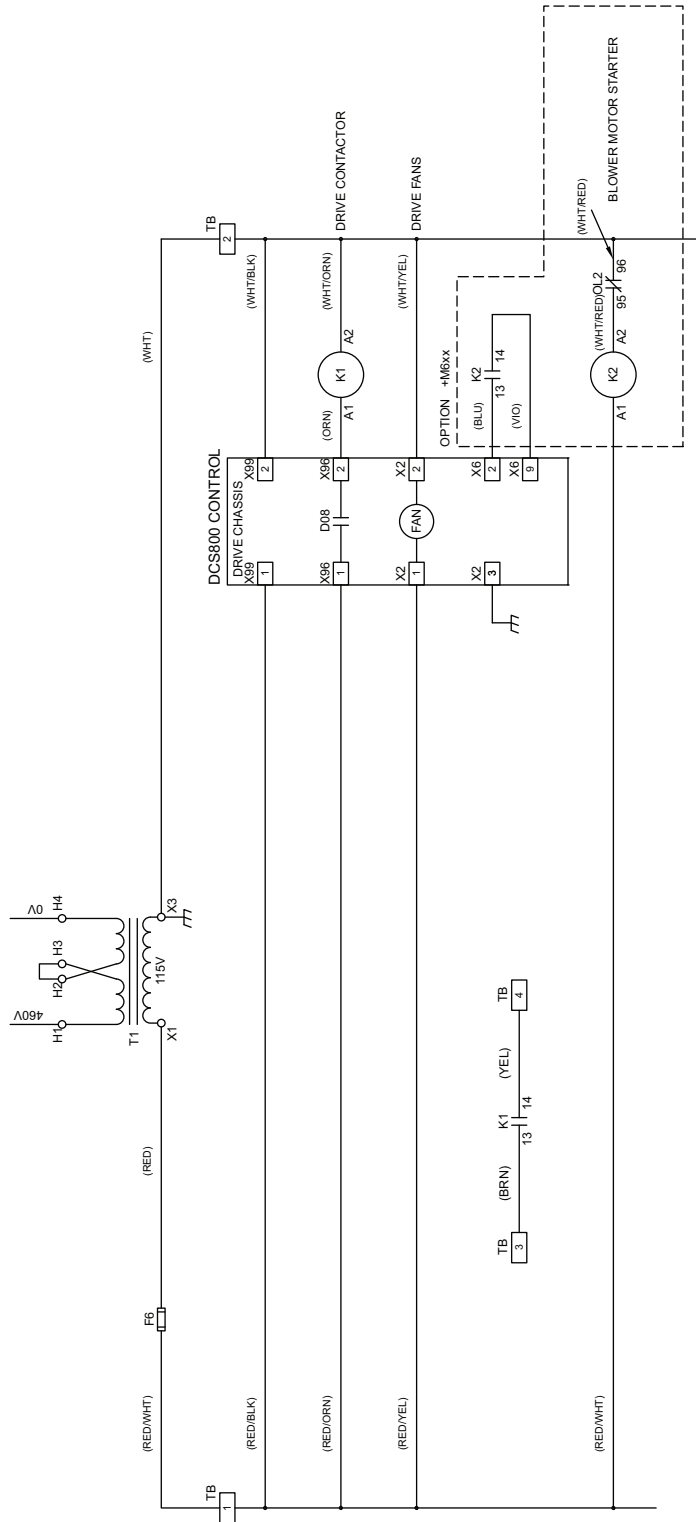

Appendix 1 — Operating instructions for blower motor thermal overload relay

TA25DU

2CDC106031M6801 (a)

en	Installation instructions	Thermal overload relay TA25DU
de	Montageanweisung	Thermisches Überlastrelais TA25DU
es	Instrucciones de montaje	Relé térmico de sobrecarga TA25DU
fr	Notice de montage	Relais thermique TA25DU
it	Istruzioni di montaggio	Relè termico TA25DU
sv	Installation och skötsel	Termiskt överlastrelä TA25DU
cn	安装说明书	热过载继电器TA25DU
ru	Инструкция по монтажу	Тепловые реле защиты от перегрузки TA25DU



ABB STOTZ-KONTAKT GmbH
 Eppelheimer Str. 82 Postfach 101680
 69123 Heidelberg 69006 Heidelberg
 Germany Germany
 Internet <http://www.abb.com/contacts>



en **Warning!** The installation and the operation of this device and any maintenance must be carried out by a qualified person in accordance with specific local standards and safety regulations. Before installing this device, read these operating instructions carefully. Don't touch live parts. To avoid damages to persons and material the devices have to be replaced in case of mechanical and/or electrical damage. These operating and installation instructions cannot claim to contain all detailed information of this product and can even not consider every possible application of the products. All statements serve exclusively to describe the product and have not to be understood as assured characteristics with legal force. Further information and data is obtainable from the catalogues and data sheets of this product, from the local ABB sales organisations as well as on the ABB homepage <http://www.abb.com>. Subject to change without prior notice. The English text applies in cases of doubt

de **Warnung!** Die Installation und die Inbetriebnahme dieses Gerätes sowie jegliche Wartungsarbeiten müssen durch eine qualifizierte Fachkraft durchgeführt werden. Dabei sind lokale Normen und Sicherheitsvorschriften zu beachten. Vor der Installation des Gerätes muss diese Betriebsanleitung aufmerksam gelesen werden. Spannung führende Teile nicht berühren. Um Personen- und Sachschäden auszuschließen, müssen die Geräte im Fall einer mechanischen und/oder elektrischen Beschädigung unbedingt ausgetauscht werden. Diese Betriebsanleitung enthält nicht sämtliche Detailinformationen zu der Produktreihe und kann auch nicht jeden Einsatzfall der Produkte berücksichtigen. Alle Angaben dienen ausschließlich der Produktbeschreibung und sind nicht als zugesicherte Eigenschaften im Rechtssinne aufzufassen. Weiterführende Informationen und Daten erhalten Sie in den Katalogen und Datenblättern der Produkte, über die örtliche ABB-Niederlassung sowie auf der ABB Homepage unter <http://www.abb.com>. Technische Änderungen jederzeit vorbehalten. In Zweifelsfällen gilt der englische Text.

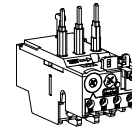
es **¡Advertencia!** La instalación y la puesta en funcionamiento de este dispositivo, así como cualquier trabajo de mantenimiento, deberán ser ejecutados por una persona competente cualificada. En esto, deberán observarse las normas locales y las normas de seguridad. No tocar piezas que se encuentren bajo tensión. Para evitar daños personales y materiales, los dispositivos deberán ser sustituidos al presentar cualquier daño mecánico y/o eléctrico. Este manual de usuario no contiene todos los datos detallados con respecto a la serie de productos, y tampoco podrá tener en cuenta cada uno de los casos de aplicación de los productos. Todas las indicaciones únicamente sirven para describir el producto y no deberán ser consideradas propiedades aseguradas en el sentido de la Ley. Información más detallada y demás datos pueden obtenerse de los catálogos y las hojas de datos de los productos, a través de la sucursal de ABB local, así como en la homepage de ABB en <http://www.abb.com>. Modificaciones técnicas reservadas en cualquier momento. En casos de duda será válido el texto inglés.

fr **Attention !** L'installation et la mise en service de cet appareil ainsi que toute opération de maintenance doivent être réalisées par une personne qualifiée, dans le respect des normes locales et des dispositions en matière de sécurité. Avant d'installer cet appareil, lisez attentivement cette notice d'utilisation. Ne pas toucher les éléments sous tension. Afin d'éviter des dommages corporels et matériels, les appareils doivent être remplacés en cas de dommage mécanique et/ou électrique.

de Cette notice d'utilisation et d'installation ne prétend pas contenir toutes les informations détaillées sur ce produit et ne peut en outre pas tenir compte de toutes les applications pouvant être faites des produits. Toutes les informations sont exclusivement destinées à décrire le produit et ne doivent pas être considérées comme des caractéristiques garanties d'un point de vue juridique. Vous trouverez des informations et des données supplémentaires dans les catalogues et les fiches techniques de ce produit ainsi que dans les filiales ABB locales ou encore sur le site Internet ABB : <http://www.abb.com>. Sous réserve de modifications techniques pouvant intervenir à tout moment. En cas de doute, c'est le texte anglais qui s'applique.

it **Avvertenza!** L'installazione e la messa in esercizio di questo apparecchio e tutti gli interventi di manutenzione dovranno essere eseguiti da tecnici qualificati, in osservazione delle norme di legge locali e delle disposizioni di sicurezza. Non toccare le parti in tensione! Per escludere lesioni a persone e danni materiali, sostituire gli apparecchi in caso di danneggiamento meccanico e/o elettrico. Le presenti istruzioni per l'uso non possono contenere tutte le informazioni di dettaglio relative alla serie di prodotti e non possono tenere conto di ogni singolo contesto applicativo. Le informazioni riportate hanno invece lo scopo esclusivo di descrivere il prodotto e non vanno interpretate come caratteristiche garantite in senso legale. Ulteriori informazioni e dati sono riportati nei cataloghi e nei fogli di dati relativi ai prodotti, ottenibili presso la filiale ABB locale oppure dal sito internet ABB all'indirizzo <http://www.abb.com>. Con riserva di modifiche tecniche! Nel caso di dubbi di interpretazione la validità è il testo inglese.

sv **Varning!** Installation och drift av denna enhet och eventuellt underhåll måste utföras av en kvalificerad person i enlighet med specifika lokala bestämmelser och säkerhetsföreskrifter. Innan denna enhet installeras ska bruksanvisningen läsas noga. Rör inte vid strömförande delar. För att undvika personskador och materiella skador måste enheten bytas vid mekanisk och/eller elektrisk skada. Det är inte något krav att denna bruks- och installationsanvisningar innehåller alla detaljerad information om produkten och kan inte heller ta hänsyn till varje möjlig användning av produkterna. All information har endast som syfte att beskriva produkten och får inte förstås som någon garanterad karakteristik med laga kraft. Ytterligare information och data finns i kataloger och datablad för denna produkt och kan beställas från lokal ABB försäljningsorganisation samt på ABB:s hemsida <http://www.abb.com>. Information kan ändras utan föregående meddelande därom. Den engelska texten gäller vid ovisshet.

cn **警告!** 此设备的安装和运行以及任何保养工作必须由具备资格的专业人员进行, 并遵守当地的有关标准和安全规则。在安装此设备前, 请仔细阅读这些使用说明。不要触摸带电部件。为避免造成人员伤亡和物质损坏, 发生机械和/或电气损坏时必须更换设备。这些使用 and 安装说明无法包含此产品的所有详细信息, 也不能涵盖产品的全部应用情况。所有陈述均仅用来描述产品, 不作为具备法律效力的属性保证。更多使用和安装说明请参看该产品的目录册和数据表。当地ABB销售处以及ABB网站 <http://www.abb.com>。如有更改, 恕不预先通知。有疑问时以英文版为准。

ru **Предупреждение!** Монтаж и ввод в эксплуатацию данного прибора, а также любые работы по техобслуживанию, должны производиться квалифицированными специалистами. При этом, необходимо соблюдать местные нормы и правила техники безопасности. Не прикасаться к деталям, которые находятся под напряжением. Чтобы исключить нанесение травм, а также материальные ущербы, в случае механических и/или электрических повреждений приборы необходимо заменить. Данное руководство не охватывает всю подробную информацию к типу и не может учитывать каждый отдельный случай применения изделия. Все данные служат лишь описанию изделия и не являются гарантированными свойствами в правовом смысле. Дальнейшие информация и данные содержатся в каталогах и технических паспортах изделий, которые Вы можете получить у местного представительства ABB, а также найти на сайте ABB <http://www.abb.com>. Оставляем за собой право на технические изменения. В случае сомнений действителен английский текст.

en	Thermal overload relay with phase loss sensitivity according to IEC/EN 60947-4-1. Ambient air temperature -25 ... +55 °C.	it	Relè di sovraccarico termico con rilevamento della perdita di fase secondo la norma IEC/EN 60947-4-1. Temperatura ambiente -25 ... +55 °C.
de	Thermisches Überlastrelais mit Phasenausfallempfindlichkeit nach IEC/EN 60947-4-1. Umgebungstemperatur -25 ... +55 °C.	sv	Termiskt överbelastningsskydd med känslighet för fasbortfall i enlighet med IEC/EN 60947-4-1. Omgivningstemperatur -25 ... +55 °C.
es	Relé térmico de sobrecarga con sensibilidad de protección de fase según IEC/EN 60947-4-1. Temperatura ambiente: -25 ... +55 °C.	cn	按照 IEC/EN 60947-4-1 的带失相灵敏性的热过载继电器。 环境温度 -25 ... +55 °C。
fr	Relais de surcharge thermique sensible à la perte de phase conformément à la norme IEC/EN 60947-4-1. Température ambiante -25 ... +55 °C.	ru	Тепловое реле защиты от перегрузки с чувствительностью против выпадения фазы соответственно IEC/EN 60947-4-1. Температура окружающей среды -25 ... +55 °C.
en	Consider the data on the label at the side of the unit.	it	Tenete conto dei dati riportati sulla targhetta conoscitiva a lato dell'apparecchio!
de	Beachten Sie die Daten auf dem seitlichen Typenschild des Geräts	sv	Beakta data på typskylten som finns på sidan av enheten.
es	Observar los datos en la placa de características lateral del dispositivo.	cn	请注意查看侧旁铭牌上的数据
fr	Veillez tenir compte des données indiquées sur la plaque signalétique située sur le côté de l'appareil.	ru	Учитывайте данные на типовой табличке прибора сбоку

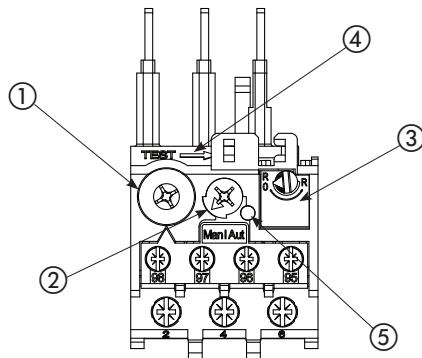
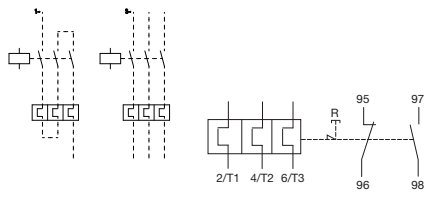
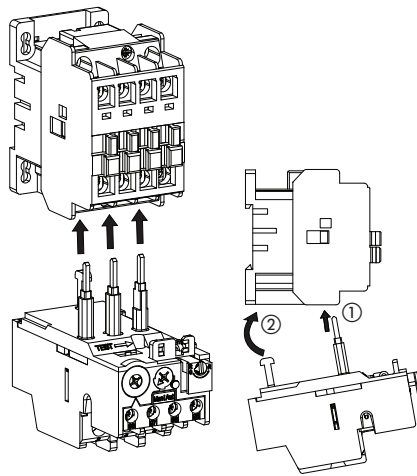

- ① **I_{nom}**
en Setting the relay to rated current of the motor
de Einstellung des Relais auf Motornennstrom
es Ajuste del relé a la corriente nominal del motor
fr Réglage du relais sur le courant nominal du moteur
it Impostazione del relé alla corrente nominale del motore
sv Ställa in reläet till motors märkström
cn 将继电器设置到马达额定电流上
ru Настройка реле на номинальный ток двигателя

② **RESET**



- en** In case of adjusting "Aut", which means automatic reset after tripping, the motor may restart automatically. This automatic restart could injure persons and damage material.
- de** Bei Einstellung "Aut", d. h. automatische Rückstellung nach einer Auslösung kann der Motor automatisch wieder anlaufen. Dieser automatische Wiederanlauf kann Personen verletzen und zu Sachschäden führen.
- es** Con el ajuste "Aut", es decir: restablecimiento automático después de una activación, el motor podrá volver a arrancar automáticamente. Este nuevo arranque automático podrá causar lesiones en personas y daños materiales.
- fr** En cas de réglage "Aut", c.-à-d. réinitialisation automatique après un déclenchement, il se peut que le moteur redémarré automatiquement. Ce redémarrage automatique peut engendrer des blessures corporelles ainsi que des dommages matériels.
- it** Vid inställning av „Aut“, d.v.s. automatisk återställning efter en utlösning, kan motorn starta automatiskt. Denna automatiska start kan orsaka skada på person och materiella skador.
- sv** Vid inställning av „Aut“, d.v.s. automatisk återställning efter en utlösning, kan motorn starta automatiskt. Denna automatiska start kan orsaka skada på person och materiella skador.
- cn** 设置为“Aut”时，即意为触发后自动复位，马达会自动重新启动。该自动重新启动可能会造成人员受伤和物质损坏。
- ru** В случае установки на "Aut", т.е. автоматический сброс после срабатывания, может произойти автоматический запуск двигателя. Вследствие автоматического запуска возможны травмы, а также материальные ущербы.

③ **RESET-STOP**

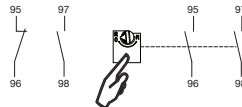

③ **RESET**



④ **TEST**

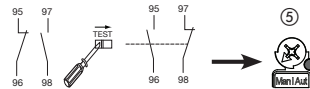

TA25DU-0.16 ...11									
2/T1 4/T2 6/T3	M4 1.4 ... 2 Nm 12 lb.in	∅ 6.5 mm	Pozi- drive No. 2	1 x 0.75 ... 4.0 mm ² 2 x 0.75 ... 4.0 mm ²	1 x 0.75 ... 4.0 mm ² 2 x 0.75 ... 4.0 mm ² 1/2 x AWG 16 ...14	1 x 0.75 ... 4.0 mm ² 2 x 0.75 ... 4.0 mm ²	1 x 0.75 ... 4.0 mm ² 2 x 0.75 ... 4.0 mm ²	12 mm	
95 - 96 97 - 98	M3.5 0.8 ... 1.3 Nm 12 lb.in	∅ 5.5 mm		1/2 x 0.75 ... 4.0 mm ²	1/2 x 0.75 ... 2.5 mm ² 1/2 x AWG 18 ...14	1/2 x 0.75 ... 2.5 mm ²	1/2 x 0.75 ... 2.5 mm ²		9 mm
TA25DU-14 ... 25									
2/T1 4/T2 6/T3	M4 1.4 ... 2 Nm 12 lb.in	∅ 6.5 mm		1/2 x 1.5... 6.0 mm ²	1/2 x 1.5 ... 4.0 mm ² 1/2 x AWG 14 ...10	1/2 x 1.5 ... 4.0 mm ²	1/2 x 1.5 ... 4.0 mm ²	12 mm	
95 - 96 97 - 98	M3.5 0.8 ... 1.3 Nm 12 lb.in	∅ 5.5 mm		1/2 x 0.75 ... 4.0 mm ²	1/2 x 0.75 ... 2.5 mm ² 1/2 x AWG 18 ...14	1/2 x 0.75 ... 2.5 mm ²	1/2 x 0.75 ... 2.5 mm ²	9 mm	
DX25 (TA25DU-32)									
	M5 2.5 ... 3.2 Nm 20 lb.in	∅ 6.5 mm		1 x 1.5 ... 10.0 mm ² 1 x AWG 10 ... 8	1/2 x 1.5 ... 6.0 mm ² 1 x AWG 10 ... 8	1/2 x 1.5 ... 6.0 mm ²	1/2 x 1.5 ... 6.0 mm ²	15 mm	

TA42DU / TA75DU**2CDC106049M6801 (a)**

en Installation instructions
de Montageanweisung
es Instrucciones de montaje
fr Notice de montage
it Istruzioni di montaggio
sv Installation och skötsel
cn 安装说明书
ru Инструкция по монтажу

Thermal overload relay TA42DU / TA75DU
Thermisches Überlastrelais TA42DU / TA75DU
Relé térmico de sobrecarga TA42DU / TA75DU
Relais thermique TA42DU / TA75DU
Relè termico TA42DU / TA75DU
Termiskt överlastrelä TA42DU / TA75DU
热过载继电器TA42DU / TA75DU
Тепловые реле защиты от перегрузки TA42DU / TA75DU



ABB STOTZ-KONTAKT GmbH
Eppelheimer Str. 82 Postfach 101680
69123 Heidelberg 69006 Heidelberg
Germany Germany
Internet <http://www.abb.com/contacts>



- en Warning!** The installation and the operation of this device and any maintenance must be carried out by a qualified person in accordance with specific local standards and safety regulations. Before installing this device, read these operating instructions carefully. Don't touch live parts. To avoid damages to persons and material the devices have to be replaced in case of mechanical and/or electrical damage. These operating and installation instructions cannot claim to contain all detailed information of this product and can even not consider every possible application of the products. All statements serve exclusively to describe the product and have not to be understood as assured characteristics with legal force. Further information and data is obtainable from the catalogues and data sheets of this product, from the local ABB sales organisations as well as on the ABB homepage <http://www.abb.com>. Subject to change without prior notice. The English text applies in cases of doubt.
- de Warnung!** Die Installation und die Inbetriebnahme dieses Gerätes sowie jegliche Wartungsarbeiten müssen durch eine qualifizierte Fachkraft durchgeführt werden. Dabei sind lokale Normen und Sicherheitsvorschriften zu beachten. Vor der Installation des Gerätes muss diese Betriebsanleitung aufmerksam gelesen werden. Spannung führende Teile nicht berühren. Um Personen- und Sachschäden auszuschließen, müssen die Geräte im Fall einer mechanischen und/oder elektrischen Beschädigung unbedingt ausgetauscht werden. Diese Betriebsanleitung enthält nicht sämtliche Detailinformationen zu der Produktreihe und kann auch nicht jeden Einsatzfall der Produkte berücksichtigen. Alle Angaben dienen ausschließlich der Produktbeschreibung und sind nicht als zugesicherte Eigenschaften im Rechtssinne aufzufassen. Weiterführende Informationen und Daten erhalten Sie in den Katalogen und Datenblättern der Produkte, über die örtliche ABB-Niederlassung sowie auf der ABB Homepage unter <http://www.abb.com>. Technische Änderungen jederzeit vorbehalten. In Zweifelsfällen gilt der englische Text.
- es ¡Advertencia!** La instalación y la puesta en funcionamiento de este dispositivo, así como cualquier trabajo de mantenimiento, deberán ser ejecutados por una persona competente cualificada. En esto, deberán observarse las normas locales y las normas de seguridad. No tocar piezas que se encuentren bajo tensión. Para evitar daños personales y materiales, los dispositivos deberán ser sustituidos al presentar cualquier daño mecánico y/o eléctrico. Este manual de usuario no contiene todos los datos detallados con respecto a la serie de productos, y tampoco podrá tener en cuenta cada uno de los casos de aplicación de los productos. Todas las indicaciones únicamente sirven para describir el producto y no deberán ser consideradas propiedades aseguradas en el sentido de la Ley. Información más detallada y demás datos pueden obtenerse de los catálogos y las hojas de datos de los productos, a través de la sucursal de ABB local, así como en la homepage de ABB en <http://www.abb.com>. Modificaciones técnicas reservadas en cualquier momento. En casos de duda será válido el texto inglés.
- fr Attention !** L'installation et la mise en service de cet appareil ainsi que toute opération de maintenance doivent être réalisées par une personne qualifiée, dans le respect des normes locales et des dispositions en matière de sécurité. Avant d'installer cet appareil, lisez attentivement cette notice d'utilisation. Ne pas toucher les éléments sous tension. Afin d'éviter des dommages corporels et matériels, les appareils doivent être remplacés en cas de dommage mécanique et/ou électrique. Cette notice d'utilisation et d'installation ne prétend pas contenir toutes les informations détaillées sur ce produit et ne peut en outre pas tenir compte de toutes les applications pouvant être faites des produits. Toutes les informations sont exclusivement destinées à décrire le produit et ne doivent pas être considérées comme des caractéristiques garanties d'un point de vue juridique. Vous trouverez des informations et des données supplémentaires dans les catalogues et les fiches techniques de ce produit ainsi que dans les filiales ABB locales ou encore sur le site Internet ABB : <http://www.abb.com>. Sous réserve de modifications techniques pouvant intervenir à tout moment. En cas de doute, c'est le texte anglais qui s'applique.
- it Avvertenze!** L'installazione e la messa in esercizio di questo apparecchio e tutti gli interventi di manutenzione dovranno essere eseguiti da tecnici qualificati, in osservanza delle norme di legge locali e delle disposizioni di sicurezza. Non toccare le parti in tensione! Per escludere lesioni a persone e danni materiali, sostituire gli apparecchi in caso di danneggiamento meccanico e/o elettrico. Le presenti istruzioni per l'uso non possono contenere tutte le informazioni di dettaglio relative alla serie di prodotti e non possono tenere conto di ogni singolo contesto applicativo. Le informazioni riportate hanno invece lo scopo esclusivo di descrivere il prodotto e non vanno interpretate come caratteristiche garantite in senso legale. Ulteriori informazioni e dati sono riportati nei cataloghi e nei fogli di dati relativi ai prodotti, ottenibili presso la filiale ABB locale oppure dal sito internet ABB all'indirizzo <http://www.abb.com>. Con riserva di modifiche tecniche! Nel caso di dubbi di interpretazione ha validità il testo inglese.
- sv Varning!** Installation och drift av denna enhet och eventuellt underhåll måste utföras av en kvalificerad person i enlighet med specifika lokala bestämmelser och säkerhetsföreskrifter. Innan denna enhet installeras ska bruksanvisningen läsas noga. För inte vid strömförande delar. För att undvika personskador och materiella skador måste enheten bytas vid mekanisk och/eller elektrisk skada. Det är inte något krav att denna bruks- och installationsanvisningar innehåller all detaljerad information om produkten och kan inte heller ta hänsyn till varje möjlig användning av produkterna. All information har endast som syfte att beskriva produkten och får inte förstås som någon garanterad karakteristik med laga kraft. Ytterligare information och data finns i kataloger och datablad för denna produkt och kan beställas från lokal ABB försäljningsorganisation samt på ABB:s hemsida <http://www.abb.com>. Information kan ändras utan föregående meddelande. Den engelska texten gäller vid ovisshet.
- cn 警告!** 此设备的安装和运行以及任何保养工作必须由具备资格的专业人员进行, 并遵守当地的有关标准和安全规则。在安装此设备前, 请仔细阅读这些使用说明。不要触摸带电部件, 为避免造成人员伤害和物质损坏, 发生机械和/或电气损坏时必须更换设备。这些使用说明无法包含此产品的所有详细信息, 也不能涵盖产品的全部应用情况。所有陈述均仅用来描述产品, 不作为具备法律效力属性的保证。更多信息和数据请参阅该产品的目录册和数据表, 当地ABB销售处以及ABB网站 <http://www.abb.com>。如有更改, 恕不预先通知。有疑问时以英文版为准。
- ru Предупреждение!** Монтаж и ввод в эксплуатацию данного прибора, а также любые работы по техобслуживанию, должны производиться квалифицированными специалистами. При этом, необходимо соблюдать местные нормы и правила техники безопасности. Не прикасаться к деталям, которые находятся под напряжением. Чтобы исключить нанесение травм, а также материальные ущербы, в случае механических или электрических повреждений приборы необходимо заменить. Данное руководство не охватывает всю подробную информацию к типу изделия и не может учитывать каждый отдельный случай применения изделия. Все данные служат лишь описанию изделия и не являются гарантированными свойствами в правовом смысле. Дальнейшие информация и данные содержатся в каталогах и технических паспортах изделий, которые Вы можете получить у местного представительства ABB, а также найти на сайте ABB <http://www.abb.com>. Оставляем за собой право на технические изменения. В случае сомнений действителен английский текст.

en Thermal overload relay with phase loss sensitivity according to IEC/EN 60947-4-1. Ambient air temperature -25 ... +55 °C.	it Relé di sovraccarico termico con rilevamento della perdita di fase secondo la norma IEC/EN 60947-4-1. Temperatura ambiente -25 ... +55 °C.
de Thermisches Überlastrelais mit Phasenausfallempfindlichkeit nach IEC/EN 60947-4-1. Umgebungstemperatur -25 ... +55 °C.	sv Termiskt överbelastningskydd med känslighet för fasbortfall i enlighet med IEC/EN 60947-4-1. Omgivningstemperatur -25 ... +55 °C.
es Relé térmico de sobrecarga con sensibilidad de protección de fase según IEC/EN 60947-4-1. Temperatura ambiente: -25 ... +55 °C.	cn 按照 IEC/EN 60947-4-1 的带失相灵敏性的热过载继电器。 环境温度 -25 ... +55 °C。
fr Relais de surcharge thermique sensible à la perte de phase conformément à la norme IEC/EN 60947-4-1. Température ambiante -25 ... +55 °C.	ru Тепловое реле защиты от перегрузки с чувствительностью против выпадения фазы соответственно IEC/EN 60947-4-1. Температура окружающей среды -25 ... +55 °C.
en Consider the data on the label at the side of the unit.	it Tenete conto dei dati riportati sulla targhetta conoscitiva a lato dell'apparecchio!
de Beachten Sie die Daten auf dem seitlichen Typenschild des Geräts	sv Beakta data på typskylten som finns på sidan av enheten.
es Observar los datos en la placa de características lateral del dispositivo.	cn 请注意设备侧旁铭牌上的数据
fr Veuillez tenir compte des données indiquées sur la plaque signalétique située sur le côté de l'appareil.	ru Учитывайте данные на типовой табличке прибора сбоку

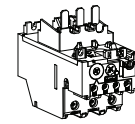
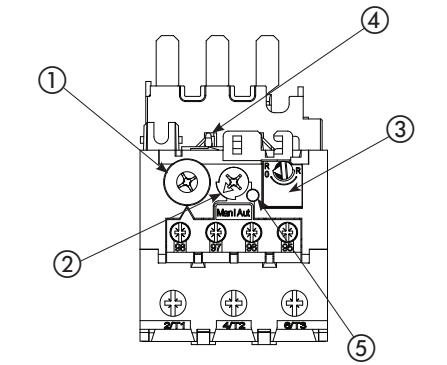
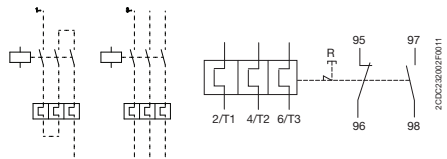
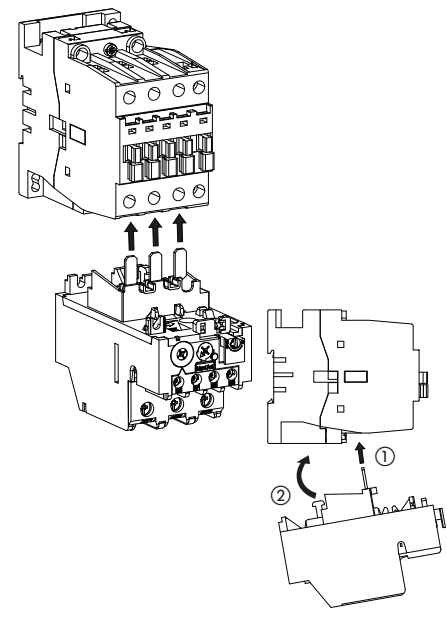

- ① **I_{nom}**
en Setting the relay to rated current of the motor
de Einstellung des Relais auf Motornennstrom
es Ajuste del relé a la corriente nominal del motor
fr Réglage du relais sur le courant nominal du moteur
it Impostazione del relé alla corrente nominale del motore
sv Ställa in reläet till motorns märkström
cn 将继电器设置到马达额定电流上
ru Настройка реле на номинальный ток двигателя

② **RESET**



- Man**
- Aut**
- en** In case of adjusting "Aut", which means automatic reset after tripping, the motor may restart automatically. This automatic restart could injure persons and damage material.
- de** Bei Einstellung "Aut", d. h. automatische Rückstellung nach einer Auslösung kann der Motor automatisch wieder anlaufen. Dieser automatische Wiederanlauf kann Personen verletzen und zu Sachschäden führen.
- es** Con el ajuste "Aut", es decir: restablecimiento automático después de una activación, el motor podrá volver a arrancar automáticamente. Este nuevo arranque automático podrá causar lesiones en personas y daños materiales.
- fr** En cas de réglage "Aut", c.-à-d. réinitialisation automatique après un déclenchement, il se peut que le moteur redémarre automatiquement. Ce redémarrage automatique peut engendrer des blessures corporelles ainsi que des dommages matériels.
- it** Vid inställning av „Aut“, d.v.s. automatisk återställning efter en utlösning, kan motorn starta automatiskt. Denna automatiska start kan orsaka skada på person och materiella skador.
- sv** Vid inställning av „Aut“, d.v.s. automatisk återställning efter en utlösning, kan motorn starta automatiskt. Denna automatiska start kan orsaka skada på person och materiella skador.
- cn** 设置为 "Aut" 时，即意为触发后自动复位，马达会自动重新启动。该自动重新启动可能会造成人员受伤和物质损坏。
- ru** В случае установки на "Aut", т.е. автоматический сброс после срабатывания, может произойти автоматический запуск двигателя. Вследствие автоматического запуска возможны травмы, а также материальные ущербы.

③ **RESET-STOP**



③ **RESET**

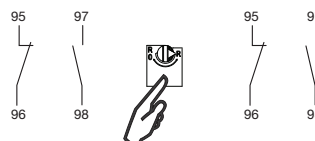

④ **TEST**

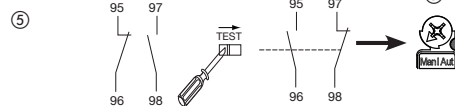

TA42DU TA75DU						
2/T1 4/T2 6/T3	M6 4.5 Nm 40 lb.in	∅ 6.5 mm	Pozidriv No. 2	1 x 2.5 ... 25 mm ² 2 x 2.5 ... 16.0 mm ²	1 x 2.5 ... 25 mm ² 2 x 2.5 ... 10.0 mm ² 1/2 x AWG 8 ...1	14 mm
95 - 96 97 - 98	M3,5 0.8 ... 1.3 Nm 12 lb.in	∅ 5.5 mm		1/2 x 0.75 ... 4.0 mm ²	1/2 x 0.75 ... 2.5 mm ² 1/2 x AWG 18 ...14	9 mm

T16

2CDC106019M6801 (b)

en Installation instructions
de Montageanweisung
es Instrucciones de montaje
fr Notice de montage
it Istruzioni di montaggio
sv Installation och skötsel
cn 安装说明书
ru Инструкция по монтажу

Thermal overload relay T16
Thermisches Überlastrelais T16
Relé térmico de sobrecarga T16
Relais thermique T16
Relé termico T16
Termiskt överlastrelä T16
热过载继电器 T16
Тепловые реле защиты от перегрузки T16

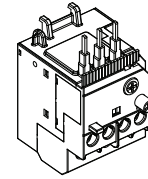

- en** **Warning!** The installation and the operation of this device and any maintenance must be carried out by a qualified person in accordance with specific local standards and safety regulations. Before installing this device, read these operating instructions carefully. Don't touch live parts. To avoid damages to persons and material the devices have to be replaced in case of mechanical and/or electrical damage. These operating and installation instructions cannot claim to contain all detailed information of this product and can even not consider every possible application of the products. All statements serve exclusively to describe the product and have not to be understood as assured characteristics with legal force. Further information and data is obtainable from the catalogues and data sheets of this product, from the local ABB sales organisations as well as on the ABB homepage <http://www.abb.com>. Subject to change without prior notice. The English text applies in cases of doubt.
- de** **Warnung!** Die Installation und die Inbetriebnahme dieses Gerätes sowie jegliche Wartungsarbeiten müssen durch eine qualifizierte Fachkraft durchgeführt werden. Dabei sind lokale Normen und Sicherheitsvorschriften zu beachten. Vor der Installation des Gerätes muss diese Betriebsanleitung aufmerksam gelesen werden. Spannung führende Teile nicht berühren. Um Personen- und Sachschäden auszuschließen, müssen die Geräte im Fall einer mechanischen und/oder elektrischen Beschädigung unbedingt ausgetauscht werden. Diese Betriebsanleitung enthält nicht sämtliche Detailinformationen zu der Produktreihe und kann auch nicht jeden Einsatzfall der Produkte berücksichtigen. Alle Angaben dienen ausschließlich der Produktbeschreibung und sind nicht als zugesicherte Eigenschaften im Rechtssinne aufzufassen. Weiterführende Informationen und Daten erhalten Sie in den Katalogen und Datenblättern der Produkte, über die örtliche ABB-Niederlassung sowie auf der ABB Homepage unter <http://www.abb.com>. Technische Änderungen jederzeit vorbehalten. In Zweifelsfällen gilt der englische Text.
- es** **¡Advertencia!** La instalación y la puesta en funcionamiento de este dispositivo, así como cualquier trabajo de mantenimiento, deberán ser ejecutados por una persona competente cualificada. En esto, deberán observarse las normas locales y las normas de seguridad. No tocar piezas que se encuentren bajo tensión. Para evitar daños personales y materiales, los dispositivos deberán ser sustituidos al presentar cualquier daño mecánico y/o eléctrico. Este manual de usuario no contiene todos los datos detallados con respecto a la serie de productos, y tampoco podrá tener en cuenta cada uno de los casos de aplicación de los productos. Todas las indicaciones únicamente sirven para describir el producto y no deberán ser consideradas propiedades aseguradas en el sentido de la Ley. Información más detallada y demás datos pueden obtenerse de los catálogos y las hojas de datos de los productos, a través de la sucursal de ABB local, así como en la homepage de ABB en <http://www.abb.com>. Modificaciones técnicas reservadas en cualquier momento. En casos de duda será válido el texto inglés.
- fr** **Attention!** L'installation et la mise en service de cet appareil ainsi que toute opération de maintenance doivent être réalisées par une personne qualifiée, dans le respect des normes locales et des dispositions en matière de sécurité. Avant d'installer cet appareil, lisez attentivement cette notice d'utilisation. Ne pas toucher les éléments sous tension. Afin d'éviter des dommages corporels et matériels, les appareils doivent être remplacés en cas de dommage mécanique et/ou électrique. Cette notice d'utilisation et d'installation ne prétend pas contenir toutes les informations détaillées sur ce produit et ne peut en outre pas tenir compte de toutes les applications pouvant être faites des produits. Toutes les informations sont exclusivement destinées à décrire le produit et ne doivent pas être considérées comme des caractéristiques garanties d'un point de vue juridique. Vous trouverez des informations et des données supplémentaires dans les catalogues et les fiches techniques de ce produit ainsi que dans les filiales ABB locales ou encore sur le site Internet ABB : <http://www.abb.com>. Sous réserve de modifications techniques pouvant intervenir à tout moment. En cas de doute, c'est le texte anglais qui s'applique.
- it** **Avvertenza!** L'installazione e la messa in esercizio di questo apparecchio e tutti gli interventi di manutenzione dovranno essere eseguiti da tecnici qualificati, in osservazione delle norme di legge locali e delle disposizioni di sicurezza. Non toccare le parti in tensione! Per escludere lesioni a persone e danni materiali, sostituire gli apparecchi in caso di danneggiamento meccanico e/o elettrico. Le presenti istruzioni per l'uso non possono contenere tutte le informazioni di dettaglio relative alla serie di prodotti e non possono tenere conto di ogni singolo contesto applicativo. Le informazioni riportate hanno invece lo scopo esclusivo di descrivere il prodotto e non vanno interpretate come caratteristiche garantite in senso legale. Ulteriori informazioni e dati sono riportati nei cataloghi e nei fogli di dati relativi ai prodotti, ottenibili presso la filiale ABB locale oppure dal sito internet <http://www.abb.com>. Con riserva di modifiche tecniche! Nel caso di dubbi di interpretazione ha validità il testo inglese.
- sv** **Varning!** Installation och drift av denna enhet och eventuellt underhåll måste utföras av en kvalificerad person i enlighet med specifika lokala bestämmelser och säkerhetsföreskrifter. Innan denna enhet installeras ska bruksanvisningen läsas noga. Rör inte vid strömförande delar. För att undvika personskador och materiel-skador måste enheten bytas vid mekanisk och/eller elektrisk skada. Det får inte något krav att denna bruks- och installationsanvisningar innehåller all detaljerad information om produkten och kan inte heller ta hänsyn till varje möjlig användning av produkterna. All information har endast som syfte att beskriva produkten och får inte förstås som någon garanterad karakteristik med laga kraft. Ytterligare information och data finns i kataloger och datablad för denna produkt och kan beställas från lokal ABB försäljningsorganisation samt på ABB:s hemsida <http://www.abb.com>. Information kan ändras utan föregående meddelande därom. Den engelska texten gäller vid ovisshet.
- cn** **警告!** 此设备的安装和运行以及任何保养工作必须由具备资格的专业人员进行,并遵守当地的有关标准和安全规则。在安装此设备前,请仔细阅读这些使用说明。不要触摸带电部件。为避免造成人员伤亡和物质损坏,发生机械和/或电气损坏时必须更换设备。这些使用和安装说明无法包含此产品的所有详细信息,也不能涵盖产品的全部应用情况。所有陈述均仅用来描述产品,不作为具备法律效力的属性保证。更多信息和数据请参阅该产品的目录册和数据表,当地ABB销售处以及ABB网站 <http://www.abb.com>。如有更改,恕不预先通知。有疑问时以英文版为准。
- ru** **Предупреждение!** Монтаж и ввод в эксплуатацию данного прибора, а также любые работы по техобслуживанию, должны производиться квалифицированными специалистами. При этом, необходимо соблюдать местные нормы и правила техники безопасности. Не прикасайтесь к деталям, которые находятся под напряжением. Чтобы исключить нанесение травм, а также материальные ущербы, в случае механических и/или электрических повреждений приборы необходимо заменить. Данное руководство не охватывает всю подробную информацию к типоряду и не может учитывать каждый отдельный случай применения изделия. Все данные служат лишь описанием изделия и не являются гарантированными свойствами в правовом смысле. Дальнейшие информация и данные содержатся в каталогах и технических паспортах изделий, которые Вы можете получить у местного представительства ABB, а также найти на сайте ABB <http://www.abb.com>. Оставляем за собой право на технические изменения. В случае сомнений действителен английский текст.

en Thermal overload relay with phase loss sensitivity according to IEC/EN 60947-4-1. Ambient air temperature -25 ... +60 °C (B6/B7 -25 ... +50 °C).	it Relé di sovraccarico termico con rilevamento della perdita di fase secondo la norma IEC/EN 60947-4-1. Temperatura ambiente -25 ... +60 °C (B6/B7 -25 ... +50 °C).
de Thermisches Überlastrelais mit Phasenausfallempfindlichkeit nach IEC/EN 60947-4-1. Umgebungstemperatur -25 ... +60 °C (B6/B7 -25 ... +50 °C).	sv Termiskt överbelastningsskydd med känslighet för fasbortfall i enlighet med IEC/EN 60947-4-1. Omgivningstemperatur -25 ... +60 °C (B6/B7 -25 ... +50 °C).
es Relé térmico de sobrecarga con sensibilidad de protección de fase según IEC/EN 60947-4-1. Temperatura ambiente: -25 ... +60 °C (B6/B7 -25 ... +50 °C).	cn 按照 IEC/EN 60947-4-1 的带失相灵敏性的热过载继电器。 环境温度 -25 ... +60 °C (B6/B7 -25 ... +50 °C)。
fr Relais de surcharge thermique sensible à la perte de phase conformément à la norme IEC/EN 60947-4-1. Température ambiante -25 ... +60 °C (B6/B7 -25 ... +50 °C).	ru Тепловое реле защиты от перегрузки с чувствительностью против выпадения фазы соответственно IEC/EN 60947-4-1. Температура окружающей среды -25 ... +60 °C (B6/B7 -25 ... +50 °C).
en Consider the data on the label at the side of the unit.	it Tenete conto dei dati riportati sulla targhetta conoscitiva a lato dell'apparecchio!
de Beachten Sie die Daten auf dem seitlichen Typenschild des Geräts	sv Beakta data på typskylten som finns på sidan av enheten.
es Observar los datos en la placa de características lateral del dispositivo.	cn 请注意设备侧旁铭牌上的数据
fr Veuillez tenir compte des données indiquées sur la plaque signalétique située sur le côté de l'appareil.	ru Учитывайте данные на типовой табличке прибора сбоку

ABB STOTZ-KONTAKT GmbH
Eppelheimer Str. 82 Postfach 101680
69123 Heidelberg 69006 Heidelberg
Germany Germany
Internet <http://www.abb.com/contacts>

T16 > B6 / B7

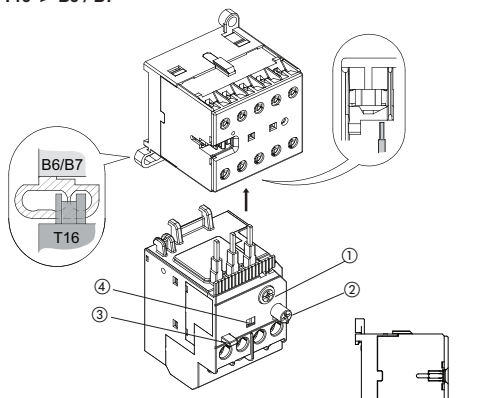

T16 > AS

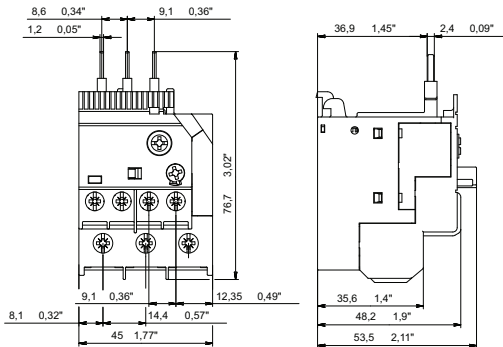
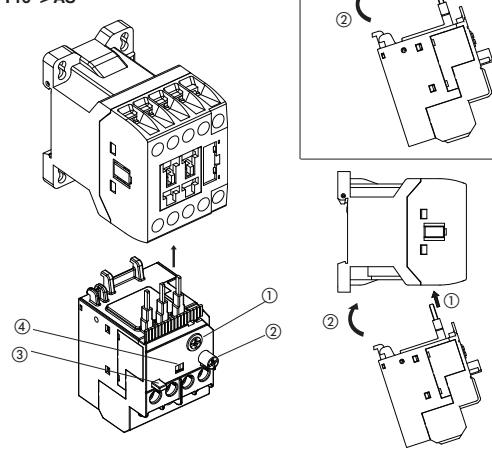

- en** ^{nom} Setting the relay to rated current of the motor
de Einstellung des Relais auf Motornennstrom
es Ajuste del relé a la corriente nominal del motor
fr Réglage du relais sur le courant nominal du moteur
it Impostazione del relé alla corrente nominale del motore
sv Ställa in reläet till motorns märkström
cn 将继电器设置到马达额定电流上
ru Настройка реле на номинальный ток двигателя

② RESET



- en** In case of adjusting "RESET A", which means automatic reset after tripping, the motor may restart automatically. This automatic restart could injure persons and damage material.
- de** Bei Einstellung "RESET A", d. h. automatische Rückstellung nach einer Auslösung kann der Motor automatisch wieder anlaufen. Dieser automatische Wiederanlauf kann Personen verletzen und zu Sachschäden führen.
- es** Con el ajuste "RESET A", es decir: restablecimiento automático después de una activación, el motor podrá volver a arrancar automáticamente. Este nuevo arranque automático podrá causar lesiones en personas y daños materiales.
- fr** En cas de réglage "RESET A", c.-à-d. réinitialisation automatique après un déclenchement, il se peut que le moteur redémarre automatiquement. Ce redémarrage automatique peut engendrer des blessures corporelles ainsi que des dommages matériels.
- it** Vid inställning av "RESET A", d.v.s. automatisk återställning efter en utlösning, kan motorn starta automatiskt. Denna automatiska start kan orsaka skada på person och materiella skador.
- sv** Vid inställning av "RESET A", d.v.s. automatisk återställning efter en utlösning, kan motorn starta automatiskt. Denna automatiska start kan orsaka skada på person och materiella skador.
- cn** 设置为 "RESET A" 时，即意为触发后自动复位，马达会自动重新启动，该自动重新启动可能会造成人员受伤和物质损坏。
- ru** В случае установки на "RESET A", т.е. автоматический сброс после срабатывания, может произойти автоматический запуск двигателя. Вследствие автоматического запуска возможны травмы, а также материальные ущербы.

③ STOP

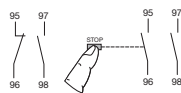

④ TEST

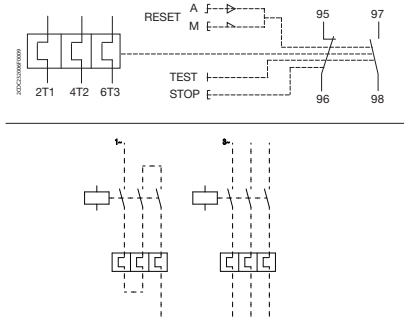
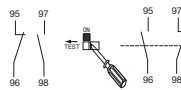

T16								
2T1 4T2 6T3	M4 1.1 ... 1.5 Nm 9 ... 13 lb.in	Ø 6.5 mm	Pozi- driv No. 2	1/2 x 0.75 ... 1.5 mm ² 1/2 x 1.5 ... 4.0 mm ² 1/2 x AWG 18 ...10	1/2 x 0.75 ... 4.0 mm ² 1/2 x AWG 18 ...10	1/2 x 0.75 ... 4.0 mm ²	1/2 x 0.75 ... 4.0 mm ²	12 mm
95 - 96 97 - 98	M3 1.0 ... 1.5 Nm 9 ... 13 lb.in	Ø 5.5 mm		1/2 x 0.75 ... 4.0 mm ² 1/2 x AWG 18 ...12	1/2 x 0.75 ... 1.0 mm ² 1/2 x 1.0 ... 2.5 mm ² 1/2 x AWG 18 ...12	1/2 x 0.75 ... 2.5 mm ²	1 x 0.75 ... 2.5 mm ² 2 x 0.75 ... 1.5 mm ²	9 mm
B6 / B7	M3 0.8 ... 1.1 Nm 7 lb.in	Ø 5.5 mm	Pozi- driv No. 1	1/2 x 1.0 ... 4.0 mm ²	1/2 x 1.0 ... 2.5 mm ² 1/2 x AWG 22 ...10	1/2 x 1.0 ... 2.5 mm ²	1 x 1.0 ... 2.5 mm ²	9 mm
AS	M3 1.0 Nm 9 lb-inn	Ø 5.5 mm	Pozi- driv No. 2	1/2 x 0.75 ... 4.0 mm ² 1/2 x AWG 18 ...10	1/2 x 0.75 ... 2.5 mm ² 1/2 x AWG 18 ...12	1/2 x 0.75 ... 2.5 mm ²	1 x 0.75 ... 2.5 mm ² 2 x 0.75 ... 1.5 mm ²	10 mm

Index

	Numerics		
230 Vac operation		22	
	A		
Accessories		33	
Air flow		13	
Analog inputs		21	
	B		
Blower Motor Starter		30, 32, 37	
	C		
Cabinet mounting		12	
Cable sizing		16	
Checklist		23	
Clearances		12, 13	
Connector locations		19	
Connectors		19	
Control circuit connections		21	
Control circuit inputs		21	
Control diagrams		35, 36	
Control transformer		22, 32	
Cooling air		12, 13	
	D		
Delivery check		11	
Digital inputs		21	
Dimensional data		24	
Dimensional drawings		25	
	E		
Electrical installation		17	
Electrical specifications		31	
Environmental specifications		31	
	F		
Factory options		10	
Fuse tightening torque		29	
Fuses		29	
	G		
Grounding		3, 18	
	H		
Heat dissipation		13	
	I		
I/O programming		21	
Installation checklist		23	
Installation warnings		2	
Insulation check		17	
	L		
Line reactors		14, 15	
Low voltage configuration		22	
	M		
Mechanical installation		4, 11	
Mechanical installation warnings		4	
	N		
Nameplate		11	
	O		
Operation		5	
	P		
Panel photographs		8	
Parameter settings		21	
Planning the electrical installation		14	
Plus codes		10	
Power diagram		34	
	R		
Reactors		14, 15	
Replacement parts		29, 30	
	S		
Safety instructions		2	
	T		
Table of contents		6	
Technical data		31	
Tightening torque		16	
Type codes		9	
	U		
Ungrounded systems		18	
	V		
Voltage specification		31	
	W		
Warnings		2	
Watts loss		13	
Weight data		24	



3AUA0000076338 REV C
Effective 07/09/2012
Subject to change without notice.
All rights reserved.

ABB Inc.

Automation Products

Low Voltage Drives

16250 West Glendale Drive

New Berlin, WI 53151

Telephone 262 785-3200

Fax 262 780-5135

Internet www.abb.us/drives

www.abb-drives.com